

SERIES 42 - SAFETY BLOCKS

PROPER SAFETY BLOCK SELECTION

All safety blocks are rated to withstand a direct static load, which is expressed as the capability of the block to support the combined weight of both the upper ram of the press and the upper die halves in an open position. Selection of the proper style and size safety block for the specific press application must be based on these considerations: (a) the static load requirement, and (b) the required safety block maximum length.

For Example:

(Press Bed Area) (Shut Height)
 $\frac{48'' \times 96'' \times 24''}{1728 \text{ cu. in./cu. ft.}}$ = 64 cu. ft. or 64 Tons displaced static load

This cubic displacement factor (1 ton per 1 cubic foot) allows for the approximate weight of the upper ram, slide assembly including adjustment device pitman arms and the approximate weight of the upper half of the die set. It also allows for a two to one safety factor.

When more than one safety block (usually on straight side presses) is used, divide the total weight by the number of safety blocks. The resulting figure is the amount of static load the safety block (s) will have to support. Please refer to the size block (xx) that should be used for load vs. length of block.

(1) To determine the length of safety block:

With the die fully open (or top of stroke) measure the space between the upper and lower die or the space between the slide face and bolster at the point where the block would be inserted... =XX" (Shut Height + Stroke)

(2) Estimating the static load:

The "rule of thumb" method for quickly estimating the static load requirement for a particular stamping press is to allow one ton of static load for each cubic foot displaced by the press bed area X the shut height of the press.

TOTAL STATIC LOAD _____ ÷ LOAD CAPACITY BLOCK _____ = # OF SAFETY BLOCKS _____

			SUGGESTED STYLES WHEN MAXIMUM EXTENDED LENGTH (XX) IS BETWEEN THESE DIMENSIONS				
STYLE	MAX. APP. RANGE	TOTAL ADJ.	3" - 9"	9" - 21"	21" - 33"	33" - 60"	ORDER PART #
WEDGES	2" - 60"	.75"	215	205	195	180	42-XXW
SHORT Adj. Screw	6" - 60"	3"	N/A	125	125	125	42-XXS
INTERMEDIATE Adj. Screw	9" - 60"	6"	N/A	N/A	125	125	42-XXI
MEDIUM Adj. Screw	12" - 60"	9"	N/A	N/A	125	125	42-XXM
LONG Adj. Screw	18" - 60"	15"	N/A	N/A	N/A	125	42-XXL
STYLE	MAX. APP. RANGE	TOTAL ADJ.	2" - 30"	9" - 21"	21" - 30"	N/A	
WEDGES	2" - 30"	.75"	35	35	35	N/A	42o-XXW
SHORT Adj. Screw	6" - 30"	3"	35	35	35	N/A	42o-XXS
INTERMEDIATE Adj. Screw	9" - 30"	6"	33	33	33	N/A	42o-XXI
MEDIUM Adj. Screw	12" - 30"	9"	30	30	30	N/A	42o-XXM
LONG Adj. Screw	18" - 30"	15"	22	20	20	N/A	42o-XXL
EXTRUSION No Screw	N/A	N/A	50	50	45	N/A	51981
			MAXIMUM STATIC LOAD IN TONS				

BLOCK HOLDER

Sheet metal holder to be attached to the machine to mount the safety block and components when not in use.
 Part No. 62814

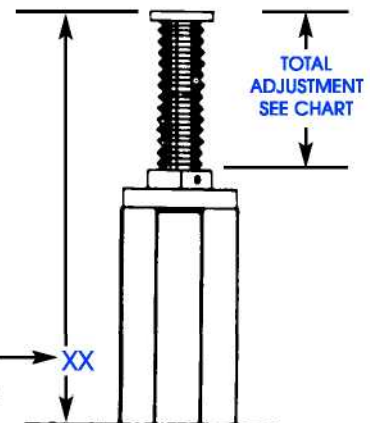

SPECIFICATIONS SUBJECT TO CHANGE WITHOUT NOTICE

NOTE: The minimum usable length of any specific block is maximum extended length (xx) minus total adjustment.
 The maximum extended length (xx) is commonly the measurement taken with the ram fully open and the slide retracted.