



Designed for Stampers by Stampers



ELECTRICALLY DRIVEN

The Pax EGD Conveyor is an oscillating type (shaker) conveyor that uses a patented elliptical geared drive to provide a robust, electrically driven, high performance conveyor. Key features of the EGD conveyors include:

No Air Consumption

- Low Operating Cost
- No Seals To Maintain
- Simple, "Plug-In" Installation

Elliptical Gear Drive In Sealed Oil Bath

- Conveying Speeds of Up To 25 fpm
- Oil Bath Protects Gearing and Provides Extremely Long Gear Life.

Simple Snap-On, Snap-Off Tray Design

- Tight, Snap On Design Provides Better Tray Movement.
- Trays Can Pivot On Bar To Allow Tray To Run On An Angle.

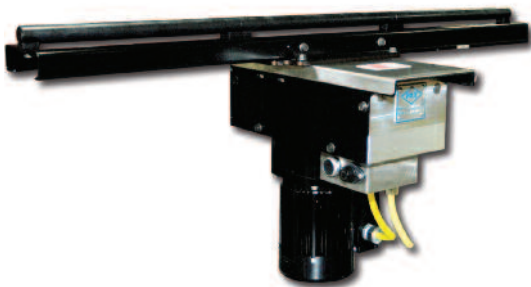

EGD-50



EGD-125



EGD-250

EGD CONVEYORS

U.S. Patents 7,975,835 B2 and 8,272,502, B2



Elliptical Geared Drive:

Elliptical Gears Are Enclosed in a Sealed Oil Bath

Electric Motor Drives the Elliptical Gears

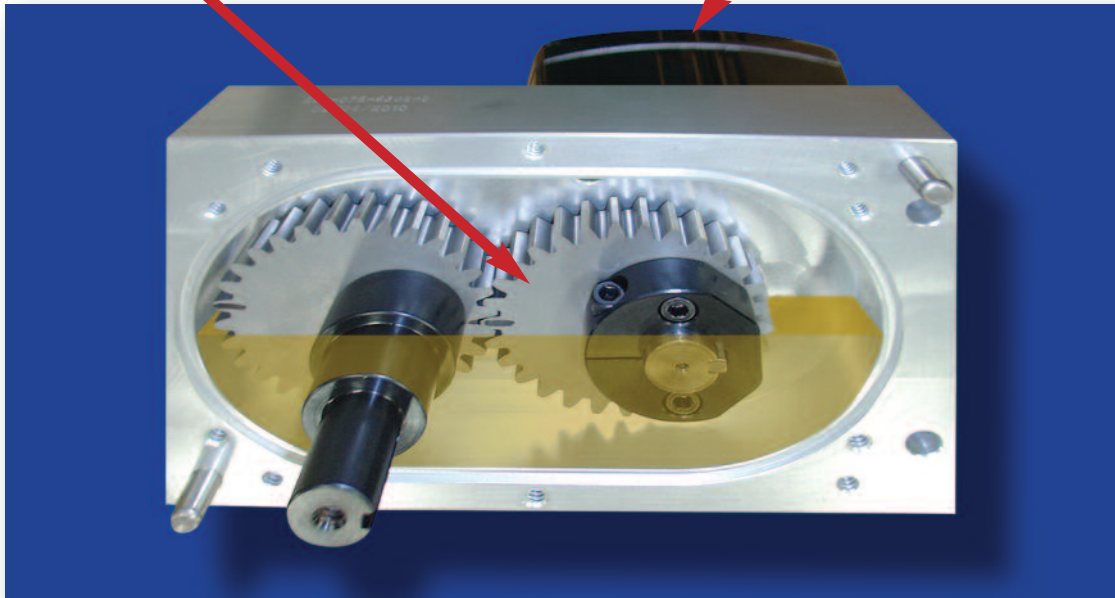

- Conveys Faster Than Typical Linkage Designs
- Gearing Does Not Have Free Clearance Inherent in Most Designs.
- Operates at Low RPM, Which Increases Bearing Life.

Snap-On Tray Design:

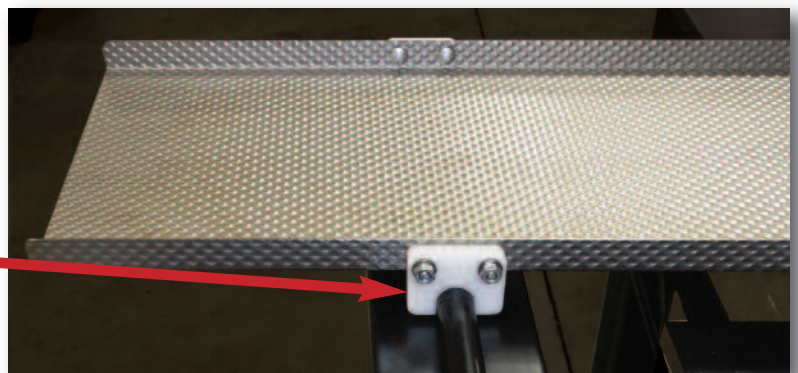
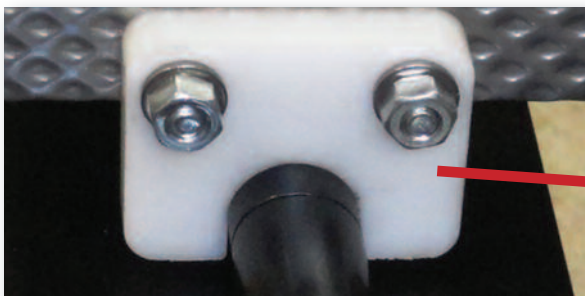

Tray brackets simply snap in place over the round portion of the cross bar without the use of tools. The machined, acetal brackets bolt to the side of the tray and are able to rotate on the cross bar in the event that the tray needs to run on a slight angle.



ELECTRICALLY DRIVEN

EGD-125:

Electric Motor Drives the Elliptical Gears

High Speed Bearings
Widely spaced to resist off center loading.
Long life due to low operating speed.

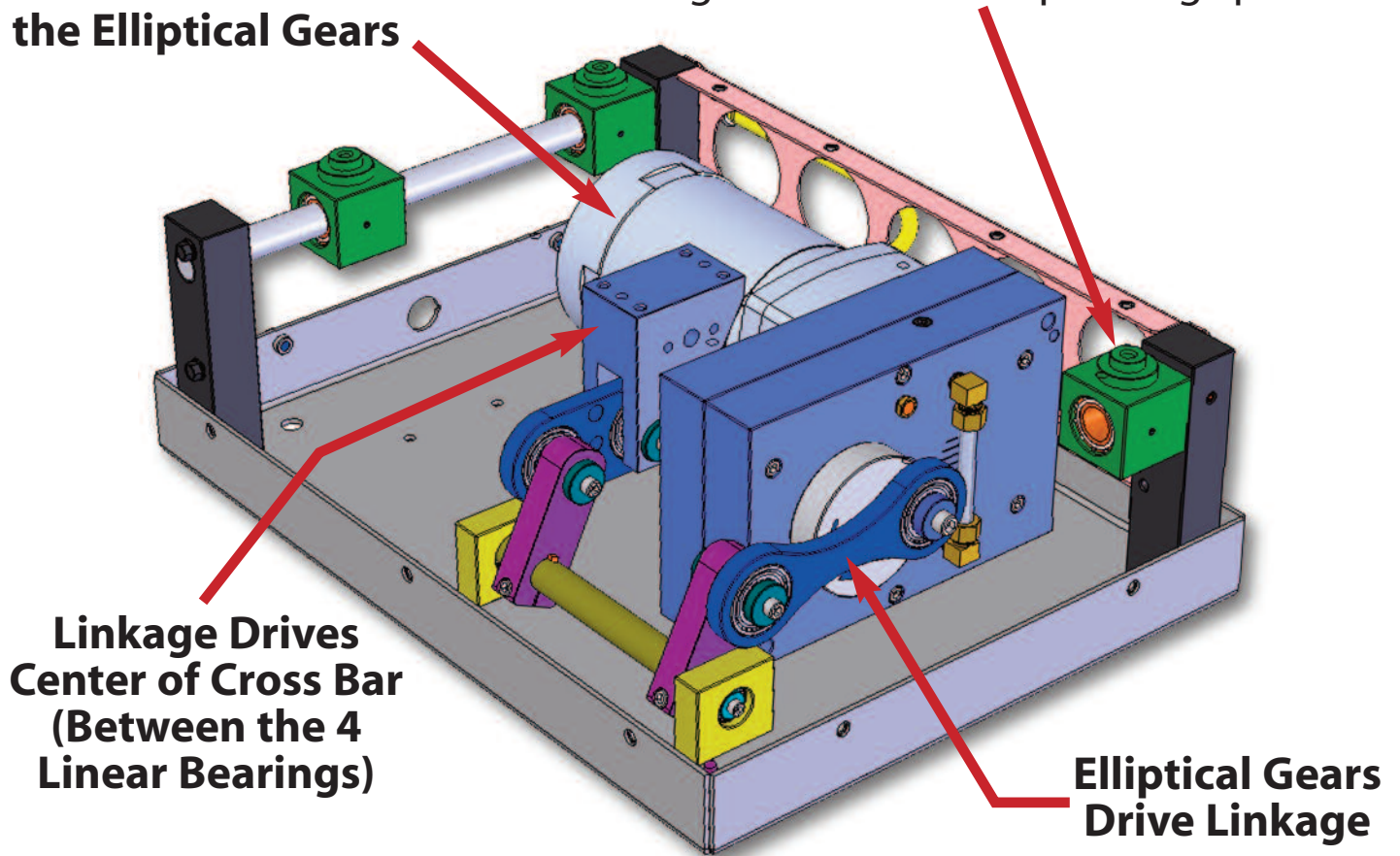

EGD-250:

Linkage Drives Directly On Widely Spaced Bearings to Further Resist Off-Center Loading.

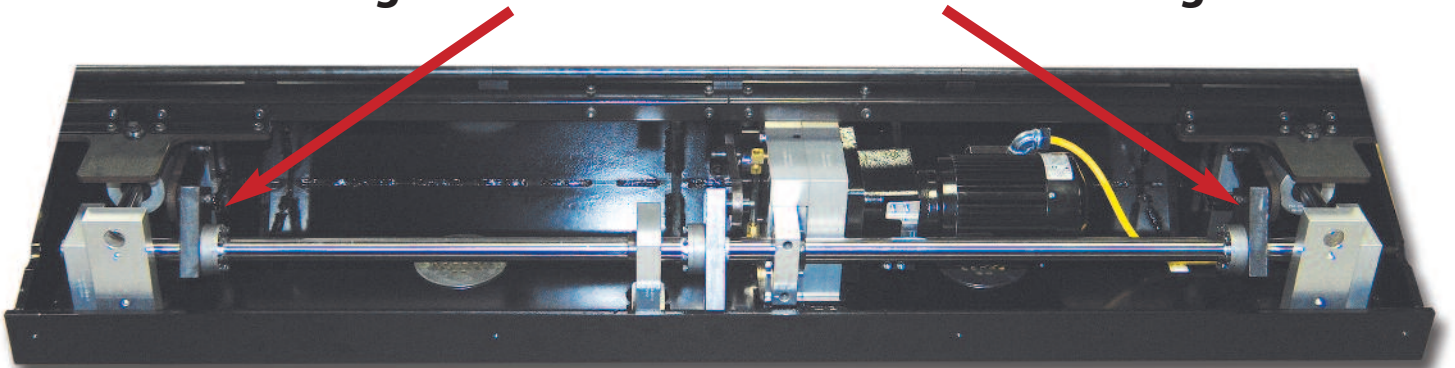



Model Specifications:

Conveyor Model	EGD-50	EGD-125	EGD-250-48	EGD-250-72
Tray Weight Capacity	50 Lbs.	125 Lbs.	250 Lbs.	250 Lbs.
Part/Scrap Capacity	100 Lbs.	250 Lbs.	500 Lbs.	500 Lbs.
Cross Bar Lengths	1' to 5' In 6" Increments	2' to 10' In 6" Increments	4' to 12' In 6" Increments	6' to 16' In 6" Increments
Unit Dimensions	16.5" H x 6.7" W x 15.6" D	9.4" H x 20" W x 15" D	11.6" H x 49" W x 17.5" D	12" H x 72" W x 18" D
Unit Weight	50 Lbs.	95 Lbs.	440 Lbs.	700 Lbs.
Motor Size	1/6 HP Gear Motor	3/8 HP Gear Motor	3/4 HP Gear Motor	3/4 HP Gear Motor
Control Type	Push Button On/Off Switch	Externally Mounted Control is Utilized For ON/OFF		
Drive Location	Bar is Driven in Center, Between the Four, Widely Spaced, Linear Bearings to Maximize Bearing Life.		Each Set of Bearings is Directly Driven in Order To Further Resist Off-Center Loading and Increase Bearing Life.	
Conveying Speed	Fixed Conveying Speed. Parts May Be Conveyed Up To 25 Feet Per Minute Depending On the Type of Part Being Conveyed and the Type and Cleanliness of the Tray.			
Voltage Input	Standard Input Voltage is 120VAC, Single Phase, 60 Hz, But Alternate Voltages Are Available.			

Options:

- T-Slot Mounting Brackets
- Custom Mounting Brackets & Stands
- Slug Shield (for EGD-125)
- Alternate Cross Bar Designs (Extruded Aluminum)
- Trays, Tray Mounting Brackets and Wear Pads

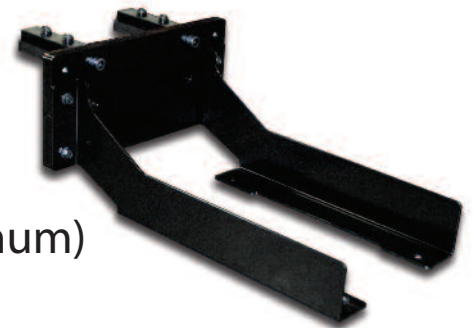

**T-Slot Bracket
For An
EGD-50**

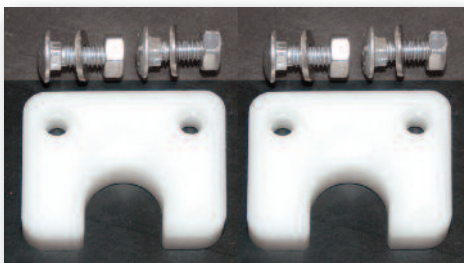

**Tray Mounting
Bracket Kit**

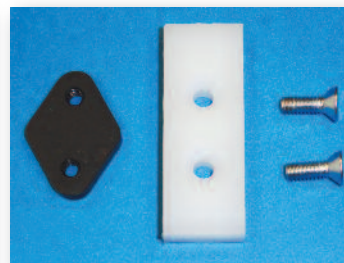

**Tray Wear
Pad Kit**



Pax Tray



The Pax Low Profile Conveyor was specifically designed for under die, part and scrap removal. This conveyor was developed in our own stamping facility and it was designed for the harsh stamping environment. Key features of this conveyor include:

Extreme Low Profile

- Only 3/8" From the Bottom of the Conveyor to Top of the belt.
Note: 2" to 2.5" of Clearance is Required to Install Conveyor.

Resistance to Die Lubricants

- Motor is Sealed to Prevent Die Lubrication From Entering.

Stopped Belt Sensor

- Optional Sensor Monitors the Belt Movement and Can Be Tied Into the Press Control to Stop the Press if the Belt Has Stopped.



Drive Configurations

Top Drive



Designed to sit directly on the press bolster, this drive can often be positioned within existing guarding. With this arrangement, material must be conveyed away from the motor.

Extended Top Drive

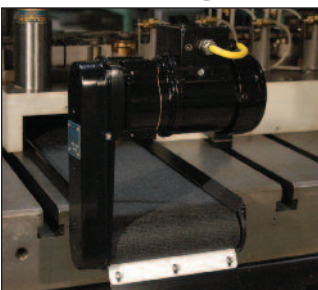

Shown With Wiper

Motor is mounted above the conveyor tray and conveyor can be arranged to either move material towards (and under) or away from the motor.

Inverted Drive



Shown With Wiper

Motor hangs below the conveyor tray and conveyor can be arranged to either move material towards or away from the motor.

Right Angle Drive

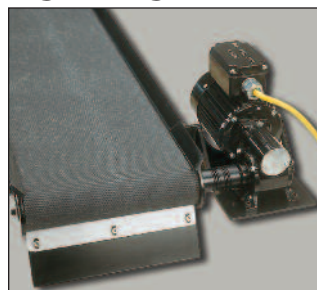

Shown With Wiper

Motor is mounted to the side of the conveyor tray and conveyor can be arranged to either move material towards or away from the motor.

PROFILE CONVEYORS



U.S. Patents 5,904,240 and 6,186,318

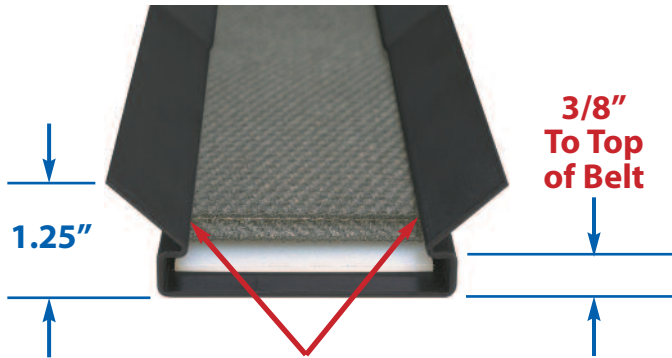

Belt Edges Protected By Tray

Flared Tray Sides Prevent Scrap From Getting Below the Belt, Increasing Belt Life.

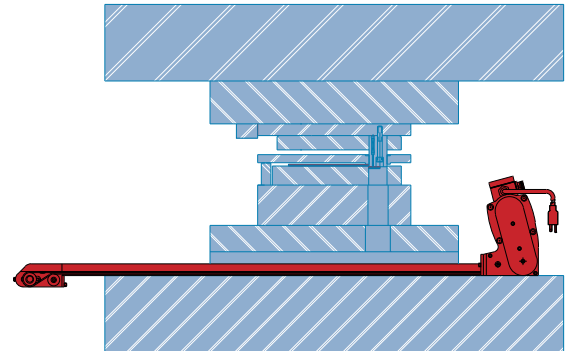

Conveyor Designed To Sit On Bolster

2½" Required For Installation of Standard Tension End, 2" For Flush Mount End.

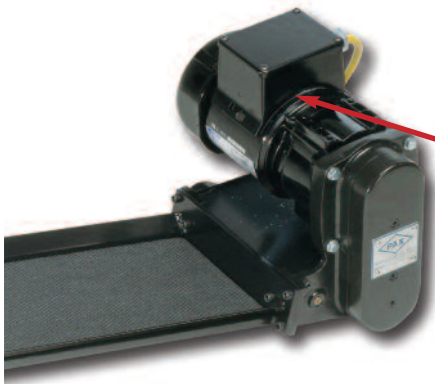

Resistant To Die Lubrication

Critical Areas Are Sealed To Prevent Die Lube From Entering

Pax Control Box Designed With Gasket Seals

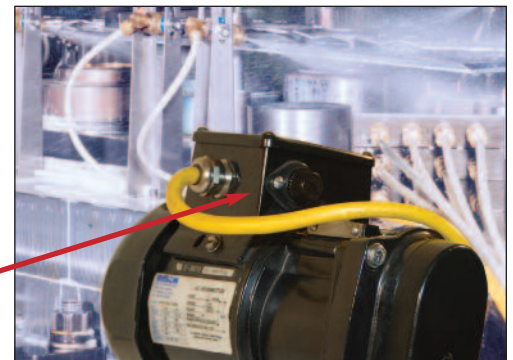

Popular Conveyor Options

Stopped Belt Sensor



Sensor is used in conjunction with the press die protection circuit to stop the press if the belt has stopped. This will prevent or minimize damage to the die and conveyor.

Wiper

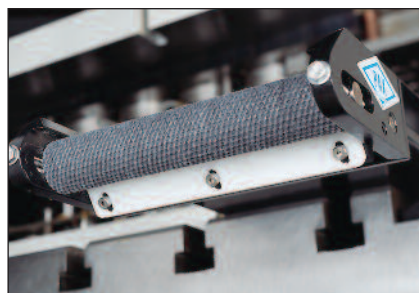

This self-adjusting wiper greatly reduces the chance of the small slugs entering between the belt and the tray, which could create premature belt wear.

Flush Mount Tension End

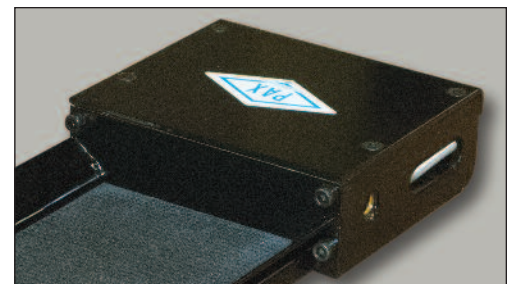

This alternative tensioning end allows the end of the conveyor to rest directly on the bolster. When this option is used, the belt direction must be towards the motor. Note that this option can only be used with the inverted, the right angle and the extended top drive arrangements.



Additional Conveyor Options:

- Special Lengths
- Variable Speeds
- Magnetic Hold Down
- Side Wipers
- Adjustable Support Stands
- Rail Extensions
- U-Shaped Tray
- Mounting Clamps
- Alternate Belt Types
- Alternate Voltage (Std. is 115V, 60 Hz)

Refer to Page 15 for Additional Information on Options

Conveyor Widths:

	NOMINAL TENSION END AND BELT WIDTHS											
	* 4"	* 5"	6"	7"	8"	9"	10"	12"	14"	16"	18"	20"
Tension End Width (A)	3.95"	4.95"	5.95"	6.95"	7.95"	8.95"	9.95"	11.95"	13.95"	15.95"	17.95"	19.95"
Belt Width (B)	2.35"	3.35"	4.35"	5.35"	6.35"	7.35"	8.35"	10.35"	12.35"	14.35"	16.35"	18.35"
Distance Motor Extends Beyond Tray (C) **	6.56"	5.56"	4.56"	3.56"	2.56"	1.56"	0.56"	—	—	—	—	—

* These Widths Include an "Out Rigger."

** This Dimension Does Not Apply to the Right Angled Drive Configuration.

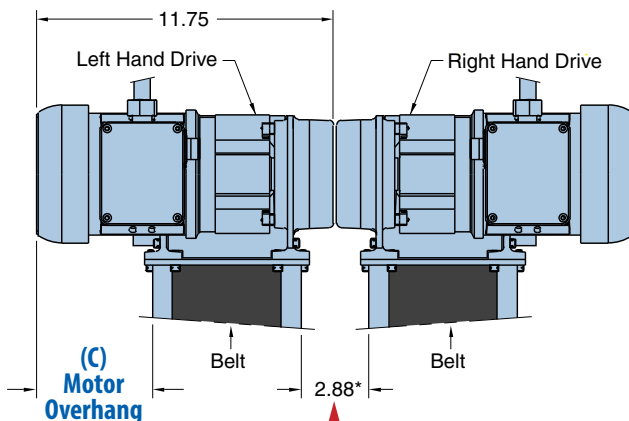
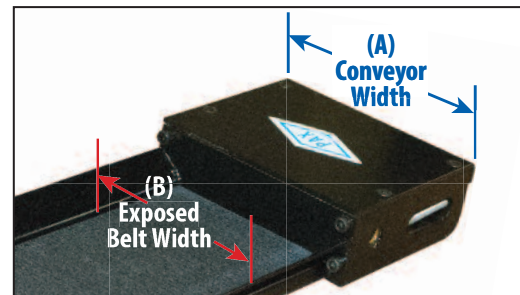
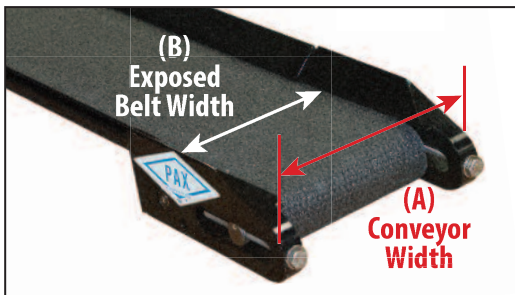

Distance between trays with 0.12" clearance between ANY two opposite drive conveyors.

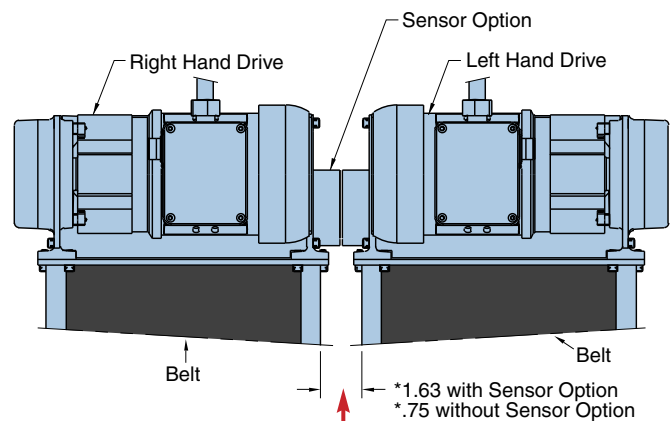

Distance between trays with 0.12" clearance between two opposite drive conveyors that are 12" wide or wider.

PROFILE CONVEYORS



U.S. Patents 5,904,240 and 6,186,318

Model Number Nomenclature & Standard Speeds

Model Number Example:

Width: 04 = Four-Inch Conveyor Width

Length: 06 = Six-Foot Exposed Belt Length

A 04 06 - S L 040

Belt Speed:

Standard Speeds Except Right Angle Drives

029 = 29 FPM 059 = 59 FPM
 034 = 34 FPM 069 = 69 FPM
 040 = 40 FPM * 080 = 80 FPM
 046 = 46 FPM 092 = 92 FPM
 054 = 54 FPM 108 = 108 FPM

Standard Speeds For Right Angle Drive

026 = 26 FPM 056 = 56 FPM
 040 = 40 FPM * 092 = 92 FPM **

Type:

- A = Top Drive*
- B = Inverted Drive, Belt Driven Towards Motor
- C = Inverted Drive, Belt Driven Away From Motor
- D = Custom Conveyor
- E = Right Angle Drive, Belt Driven Towards Motor
- F = Right Angle Drive, Belt Driven Away From Motor
- G = Extended Top Drive, Belt Driven Towards Motor
- H = Extended Top Drive, Belt Driven Away From Motor

Belt Sensor Option:

- S = Sensor
- N = No Sensor

Drive Hand

- L = Left-Hand Chain Drive *
- R = Right-Hand Chain Drive

* Standard Conveyor Configuration
 ** Requires Variable Speed Option

Standard Conveyor Lengths:

TOP DRIVE

NOMINAL LENGTH	DIMENSION		
	A	B	C
4'	48"	56"	43.2"
5'	60"	68"	55.2"
6'	72"	80"	67.2"
7'	84"	92"	79.2"
8'	96"	104"	91.2"

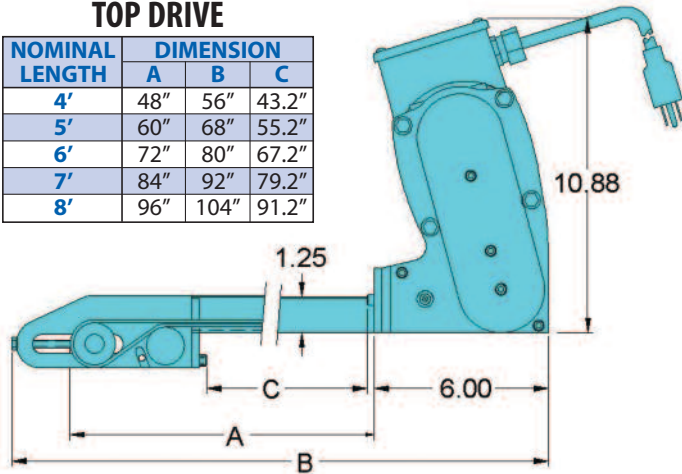

EXTENDED TOP DRIVE

NOMINAL LENGTH	DIMENSION		
	A	B	C
4'	48"	56.8"	41.5"
5'	60"	68.8"	53.5"
6'	72"	80.8"	65.5"
7'	84"	92.8"	77.5"
8'	96"	104.8"	89.5"

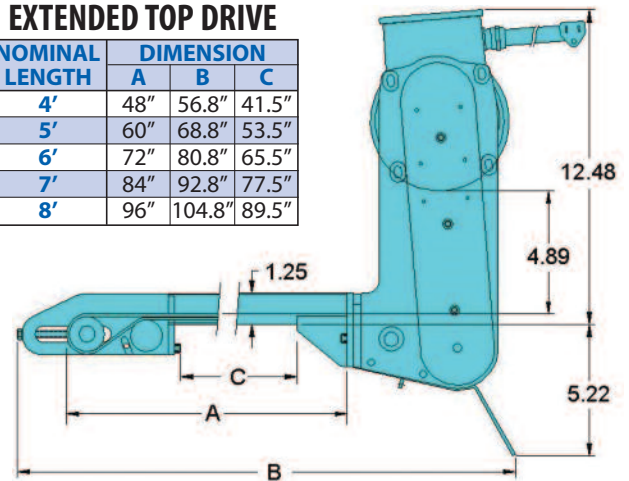

INVERTED DRIVE

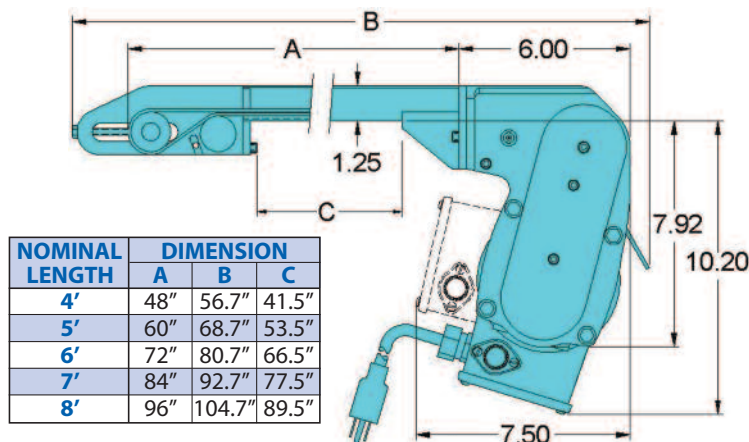

NOMINAL LENGTH	DIMENSION		
	A	B	C
4'	48"	56.7"	41.5"
5'	60"	68.7"	53.5"
6'	72"	80.7"	66.5"
7'	84"	92.7"	77.5"
8'	96"	104.7"	89.5"

RIGHT ANGLE DRIVE

NOMINAL LENGTH	DIMENSION		
	A	B	C
4'	48"	56.1"	43"
5'	60"	68.1"	55"
6'	72"	80.1"	67"
7'	84"	92.1"	79"
8'	96"	104.1"	91"

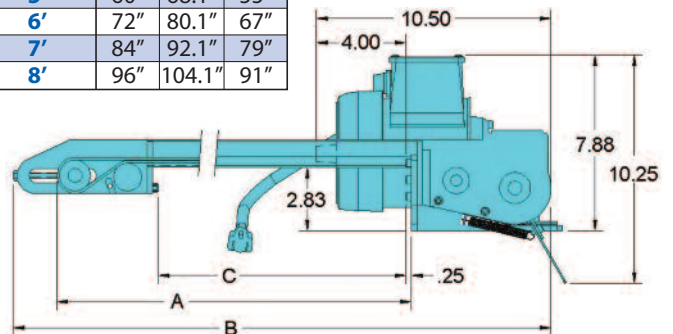

Note: For Dimensions of Additional Configurations, Please Refer to www.PaxProducts.com



The Pax Center Drive Conveyor was made for applications where a bottom drive, custom built conveyor is required. Key features of Pax Center Drive Conveyors include:

Customizable

- Conveyor Length is Made to Order (Lengths of Up to 10' Are Standard, But Longer Designs Are Available).
- Conveyor Can Be Designed With Motor Located Anywhere Along the Bottom of the Conveyor (Position is Fixed).

Ability to “Fine Tune” Belt Tracking

- Standard belt tracking is set via the belt tensioner (located below the conveyor).
- For applications that require closer than standard tracking (such as reversing applications), fine tracking adjustment mechanisms are located on all four corners of the conveyor.

Reversible

- Can be utilized to divert parts to different bins.

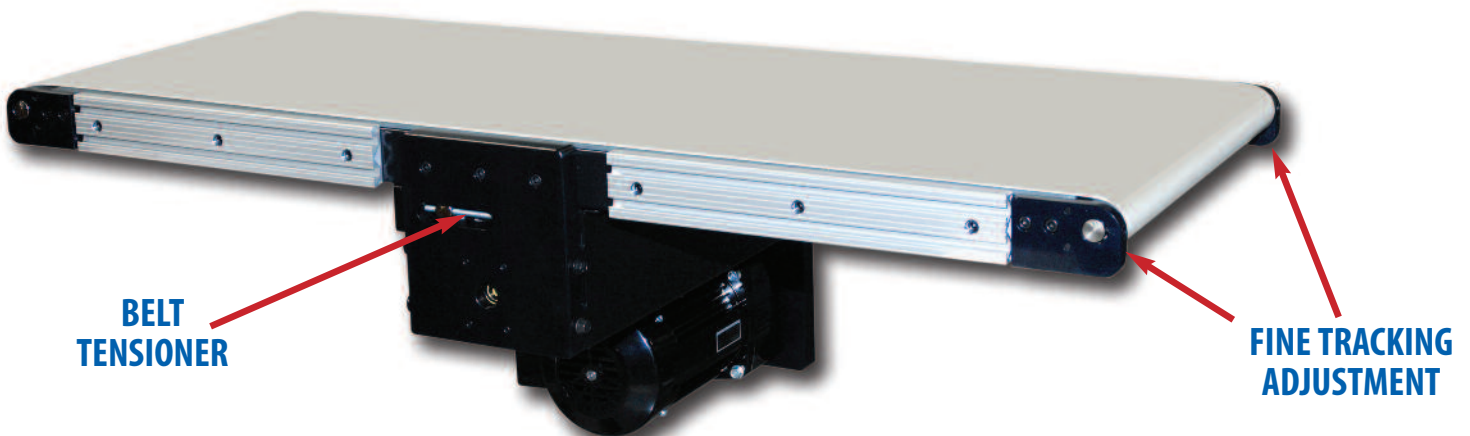

Conveyor Shown with Motor Located in Center and with Optional Aluminum Side Rails, Which Provides Mounting Flexibility

DRIVE CONVEYORS



Specifications:

	STANDARD CONVEYOR WIDTHS											
	4"	5"	6"	7"	8"	9"	10"	12"	14"	16"	18"	20"
Belt Width	2.6"	3.6"	4.6"	5.6"	6.6"	7.6"	8.6"	10.6"	12.6"	14.6"	16.6"	18.6"
Tension End Width	3.95"	4.95"	5.95"	6.95"	7.95"	8.95"	9.95"	11.95"	13.95"	15.95"	17.95"	19.95"

- Standard Lengths Up to 10', Contact Pax For Longer Lengths
- End Pulley Diameter 1.38"
- Height of Conveyor Ends 2.1" (Without Rails)
- Standard Belt Material 2-Ply Monofilament, Urethane Belt
- Standard Fixed Speeds 29, 34, 40, 46, 54, 59, 69, 80, 92, & 108 FPM
- Optional Variable Speed ... Multiple and Higher Speed Ranges Available
- Standard Voltage 115 V, Single Phase, 60 Hz

Options:

- Higher Speeds
- Alternate Voltages
- Variable Speeds
- Adjustable Support Stands
- Center Stand
- Reversing Controls
- Special Lengths
- Magnetic Hold Down
- Side Rails
- Extruded Aluminum Rails
- Side Wipers
- Parts Divider
- Alternate Belt Types

Refer to Page 15 for Additional Information on Options



Conveyor With Optional Center Stand and Reversing Drive

Typically Used to Divert Parts to a Different Parts Bin After the First Bin is Full.



Conveyor With Optional Legs, Side Rails and Motor Located Towards Left Side



PAX DRUM MOTOR

The Pax Drum Conveyor utilizes a motorized pulley to provide a customized conveyor solution for your application. Key features of the Drum Motor Conveyor design include:

Compact, Low Profile Design

- Profiles as Low as 2" Are Available.
- Motor is Located Inside the Drive Roll.

Energy Efficient, Sealed, Motorized Pulley

- Ideal For Dirty Environments.
- Uses 40% Less Energy Than a Typical, Chain-Driven Conveyor.

Customized as Required

- Conveyor Length, Width, Capacity and Speed Made to Order.
- Options Can Be Customized and Added as Required.

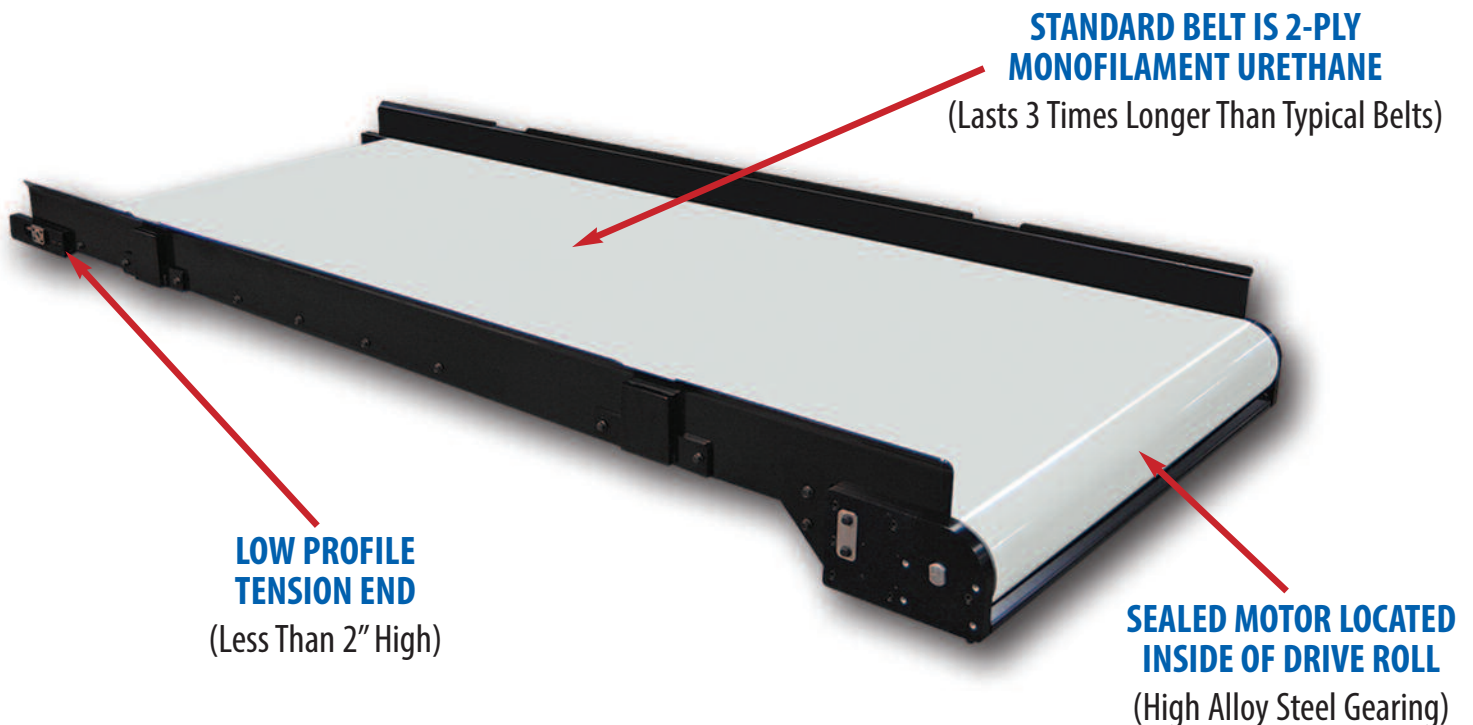



Specifications:

- Standard Belt Widths 12.5" to 48", Contact Pax For Wider Designs
(Widths With Quicker Delivery Are Listed in the Table Below)
 - Standard Lengths Up to 10', Contact Pax For Longer Lengths
 - Standard Speed Range 30 to 80 Feet Per Minute
 - Maximum Speed More Than 200 Ft./Min. With 2 Pulley Design
 - Minimum Height 2" at Tension End With Low Profile Design
 - Drum Motor Diameter 4.4"
 - Standard Belt Material 2-Ply Monofilament, Urethane Belt
 - Standard Input Voltage 115 V, Single Phase, 60 Hz Customer Input*
 - Motor Operating Voltage 240 V, Three Phase, 60 Hz*
 - Motor Gearing High Alloy Steel Gears With Helical Teeth
- * Alternate Voltages Are Readily Available.

	STANDARD CONVEYOR WIDTHS													
Belt Width	12.5"	14.4"	16.4"	18.4"	20.4"	22.3"	24.2"	26.2"	28.2"	30.2"	32.2"	34.1"	36.1"	38.1"
Tension End Width	14.4"	16.4"	18.4"	20.4"	22.3"	24.3"	26.3"	28.2"	30.2"	32.2"	34.1"	36.1"	38.1"	41.1"

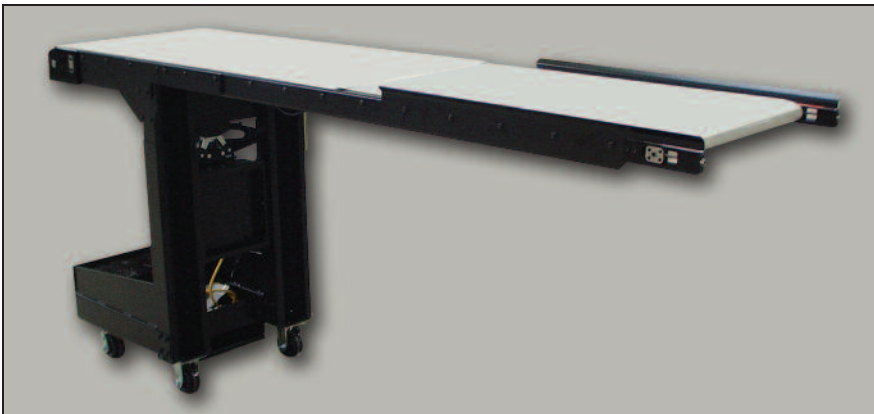

Cantilevered Mounting Design

Adjustable stand is counterweighted to balance the cantilevered conveyor, which can be rolled into position over the press bolster or other surface and then lowered as required.



High Speed, Two Pulley Design

48" Wide x 12' Long.
Speed of 165 FPM With 300 Lb. Load.

PAX DRUM MOTOR CONVEYORS

Options:

- Low Profile Tension End

The height of the conveyor tension end is less than 2" (without side or support rails). To achieve this, plain bearing are utilized in conjunction with a 1.5" diameter tension pulley and the belt tensioning mechanism extends past the conveyor belt by 3.1" to 5.1"



**Low Profile
Tension End**

- Tension End With a 2.5" Diameter Tension Pulley

This design is capable of achieving higher speeds and carrying greater loads than the low profile design and the belt tensioning mechanism does not extend past the conveyor belt (belt is flush with the end of the conveyor). To achieve this, the height of this conveyor tension end is increased to approximately 3.7" (without side or support rails) and sealed roller bearings are utilized.



**2.5" & Two Pulley
Tension End**

Belt Flush With End
of Conveyor

- Two Pulley Design With 4.4" Pulleys

This design is capable of achieving the highest speeds, carrying the greatest loads and its belt tensioning mechanism does not extend past the conveyor belt (belt is flush with the end of the conveyor). To achieve this, the height of the conveyor tension end is approximately 5.2" (without side or support rails) and sealed roller bearings are utilized.

- High Speed and High Load Designs

- Adjustable Support Stands

- Counter Weighted Support Stand

- UHMW Support Rails

- Magnetic Hold Down

- Side Rails

- Side Wipers

- Parts Divider

- Chutes and Diverters

- Alternative Belts

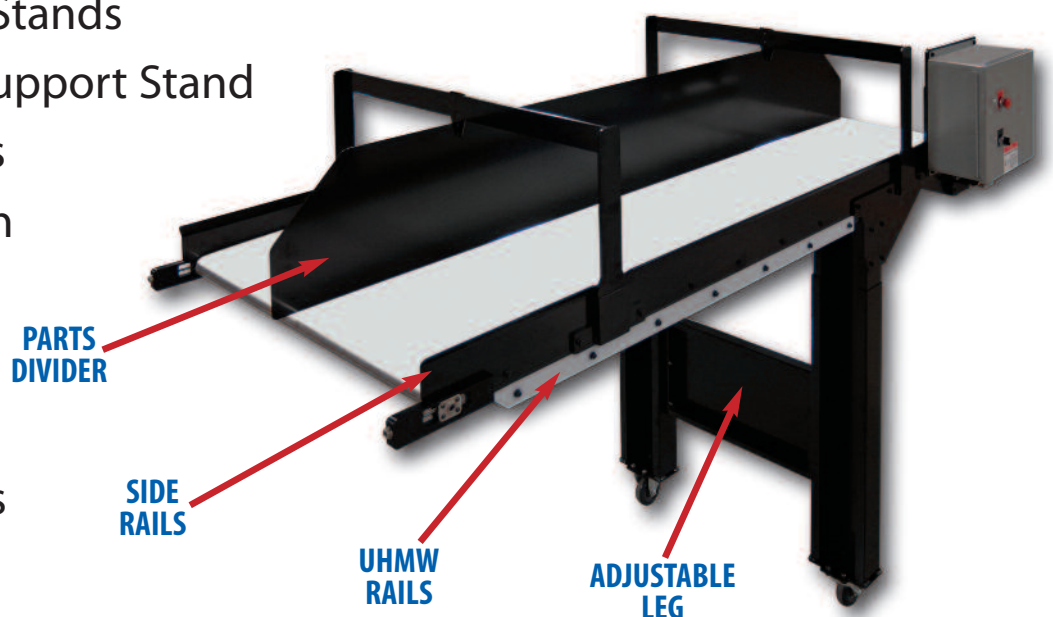

CONVEYOR OPTIONS



Side Wipers



To prevent fine scrap from getting below the sides of the belt, special side wipers can be designed that ride on and protect the sides of the belt. This option requires the use of an endless belt and, for low profile conveyors, a u-style tray must be utilized.

2-Ply, Monofilament Belt

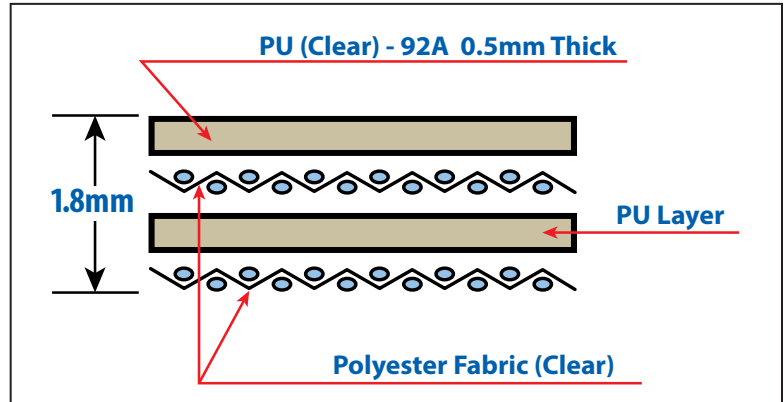

This oil resistant belt is comprised of 2 layers of clear polyurethane and 2 layers of urethane coated, polyester material, which combine for a total thickness of 1.8mm. This belt design typically lasts 3 to 4 times longer than a standard polyester belt. This belt is standard on the Pax Drum Motor and Center Drive conveyors.

Magnetic Hold Down

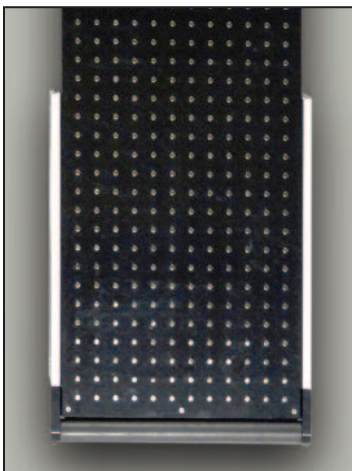

Magnets are embedded in the wear strip located directly beneath the belt. When the conveyor is running, the belt will ride across the magnets and the steel parts and scrap riding on the belt will be pulled against the belt and in the direction of the magnets.

VFD Drive



This drive is standard on the Pax EGD and Drum Motor conveyors. If variable speed is required on either the Low Profile or Center Drive conveyors, then a VFD is utilized along with a 3-phase motor.

Parts Diverters & Chutes



Manual and pneumatically operated parts diverters and part exit chutes are available and can be custom designed to meet specific application needs.

**PLEASE CONTACT PAX
REGARDING ADDITIONAL
OPTIONS AND CUSTOM DESIGNS.**



Manufacturer of Ancillary Pressroom Products

TELEPHONE: (419) 586-6948
(800) 733-6930
FAX: (419) 586-6932
WEB SITE: www.paxproducts.com

MAILING ADDRESS:
P.O. Box 257
5097 Monroe Road
Celina, Ohio 45822 U.S.A.

STOCK & DIE LUBRICATION SYSTEMS

APPLY THE EXACT AMOUNT OF LUBE,
EXACTLY WHERE IT IS REQUIRED



PRE-PRESSURIZED



V-SERIES

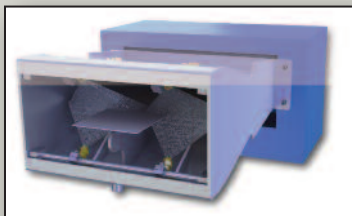

SPRAY CABINETS

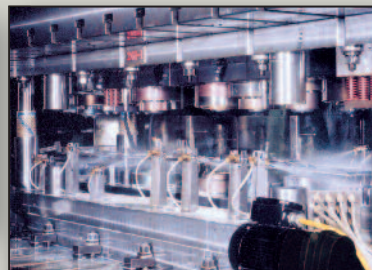

IN-DIE LUBRICATION

PRESS DOORS

PHYSICAL SAFETY BARRIER
CONTAINS & COLLECTS LUBRICATION
EASY INSTALLATION & REMOVAL



DOORS ARE AVAILABLE IN MANUAL,
POWERED, ACOUSTIC, SWING OUT AND
OTHER CUSTOM DESIGNS.

LOCAL REPRESENTATIVE:

Distributed by
Production Resources
www.production-resources.com
800-863-3164