



- Power Presses
- In Die Lubrication
- Conveyors
- Die Protection/Press Automation
- OSHA Compliant Controls & Safeguards
- Coil Handling & Feeding Equipment
- Quick Die Change
- Servo Transfer Systems

Serving: OH, PA, KY, TN, MS, AL, GA & FL Contact: Chris Jones—615-714-1000

PRESSES

EAGLE PRESS –

Mechanical Straight Sided – 300T to 3500T for Transfer, Prog die, Tandem and Tryout.
Hydraulic Presses 300T to 10,000 T for a wide range of applications.
Unitised Frame Mechanical Presses , MAX Plus 200T to 630T
Gap Frame Presses “Rhino by Eagle” 80T to 250T

BENCHMASTER – Light tonnage bench presses.

SHEARS

COLT AUTOMATION – Production and squaring shears

FEEDS

COLT AUTOMATION – Electronic roll feeds & Feeder/
Straightener combinations

SPACE SAVER FEED LINES

COLT AUTOMATION—full Feed Line capabilities within a smaller footprint—includes decoiler/straightener/feeder.
RAPID AIR – Light and medium duty air and servo feeds.
PRE- PRESS ROOM EQUIPMENT—Affordable air and servo’s

QUICK DIE CHANGE SYSTEMS (QDC)

GREEN VALLEY – Die carts , Die racks, Bolster extensions, T-tables, die handlers, & Pneumatic die lifters
PASCAL – Hydraulic clamps, die lifters, bolster extensions.
OPTIMA – Mechanical & hydraulic clamps, die transfer systems

COIL PROCESSING EQUIPMENT

COLT AUTOMATION— Feeds, Reels, Straighteners, Cradles, Cut to length lines,
RAPID AIR – Reels, Straighteners, Pallet decoilers.
ACCRA WIRE – Heavy duty pallet decoilers..
PRESS ROOM EQUIPMENT— Value priced reels, straighteners, cradles & choppers
CALDWELL – Coil hooks, lifters, & upenders
COIL-TEK – Ultra-Sonic loop controls & rewind systems

TRANSFER SYSTEMS & UNLOADERS

SYRON/NORGREN- Transfer fingers, Sensors, & Suction cups
BACHHUBER – Mechanical & servo press unloaders
LINEAR TRANSFER AUTOMATION—In die servo and press to press programmable transfer systems. Destackers, Automation.

PARTS & DIE WASHING SYTEMS

AQUEOUS PART WASHERS.

MARK ONE—Surface preparation systems: blank/coil washers, programmable spray lubrication systems.
PAX PRODUCTS—Die washing systems

HYDRAULIC SHOCK DAMPERS

W-TECHNOLOGIES - Prevent snap-thru and reverse shock loads.

SHOCK, VIBRATION, & LEVELING MOUNTS

VIBRO DYNAMICS – Press mounts
UNISORB – General purpose machinery mounts

SAFETY EQUIPMENT FOR OSHA/ANSI COMPLIANCE

SHADOW LIGHT CURTAINS

WINTRISS – Clutch/brake controls
LINEAR - Hydraulic Press Control Upgrades
ROCKFORD SAFETY- Laser scanners for area safeguarding. Hand tools, Riveter & spot welder guarding devices.
MILLEREDGE – Pressure sensitive safety mats.
PROTECH – Restraints, Press brake guarding & Safety blocks.
DIE SAFETY BLOCKS- Wedge and adjustable styles
WIRECRAFTERS – Woven & welded wire perimeter guards.
LAZERSAFE- Safeguarding for hydraulic press brakes
PAX DIE DOORS - Safeguards and lubricant containment

AUTOMATION—

Linear - turnkey automation project & systems integration

LUBRICATION SYSTEMS

PAX – Airless and roller coater stock lubrication systems. Filter and exhaust systems

DATA COLLECTION /OEE MONITORING

ShopFloorConnect – software & machine interfaces to collect production, setup, downtime & overall equipment effectiveness information from production machinery.

PRESS AUTOMATION CONTROLS

WINTRISS – SmartPAC Pro Press Automation Controls
AutoSET 1500 – Tonnage Monitors.
RAMPAC – Shut height and counterbalance controls.
ProPAC – In-Die measurement quality control system.
DiPRO 1500 – Die protection systems
LINEAR —Mechanical & hydraulic PLC press controls.
HTM ELECTRONICS—Die protection sensors - digital & analog proximity & optical
LUMBERG—Connectors & quick connection systems
PRIME CONTROLS—Double sheet detection
SYRON/NORGREN – Thread detection systems
GEMCO & KAMCO – Rotary cam switches.

CONVEYORS & MATERIAL HANDLING

PAX – Low profile slug, part and scrap conveyors. Drum motor and oscillating (EGD shaker conveyors)
NEW LONDON – Steel hinge & wire mesh belt conveyors.
DORNER – Low profile belted conveying systems. LPZ adjustable angle conveyors.
TITAN – Heavy Duty belted and roller conveyors.
MPI – Beltless shaker slug conveyors, magnetic slider bed, and magnetic belted conveyors

SOUTHWORTH— Lift tables, upenders, turntables, container tilters, stackers, & pallet handling equipment.
CALDWELL—Coil hooks, web & wire mesh below hook lifters, vacuum lifters, booms, and beams.
MARK ONE—multi lane, end of line, telescoping, and indexing conveying systems,

CONCRETE & STEEL CONSTRUCTION

DELTA INDUSTRIAL— Foundations, press pits, coil loop pits, steel mezzanines, concrete flat work, machinery installations.

SERVICES

- **TURNKEY INSTALLATIONS**
- **IN PLANT TRAINING SEMINARS**
- **DIE PROTECTION CONSULTATION**

WINTRISS CONTROLS



MPI ELECTRIC SHAKER & CONVEYORS

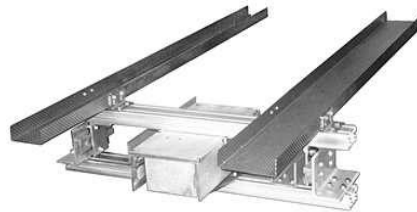

PAX IN DIE LUBRICATION SYSTEMS



RAPID AIR FEEDS, REELS, & STRAIGHTENERS

COLT AUTOMATION COIL HANDLING AND FEEDING SYSTEMS

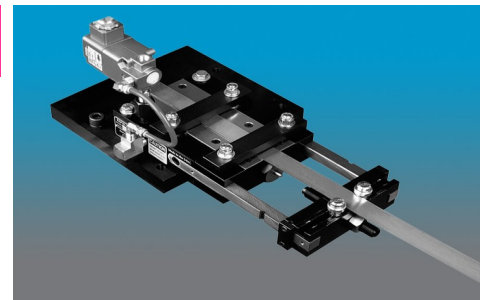
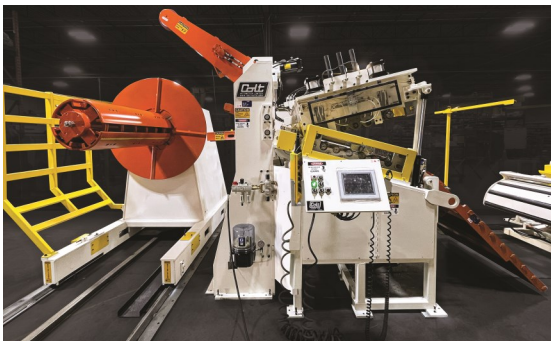

DORNER LOW PROFILE CONVEYORS

Helping You Get It Done, Today.

Your number one resource for:

- Conveyors
- Application Expertise
- Engineering Assistance
- Installation
- Service



EAGLE STRAIGHTSIDE & GAP MECHANICAL, HYDRAULIC, AND SERVO PRESSES

Your local contact is Chris Jones - 615-714-1000
Production Resources Main Office (800)863-3164
E-mail: sea-jay@pri-mailbox.com * sales55@pri-mailbox.com