

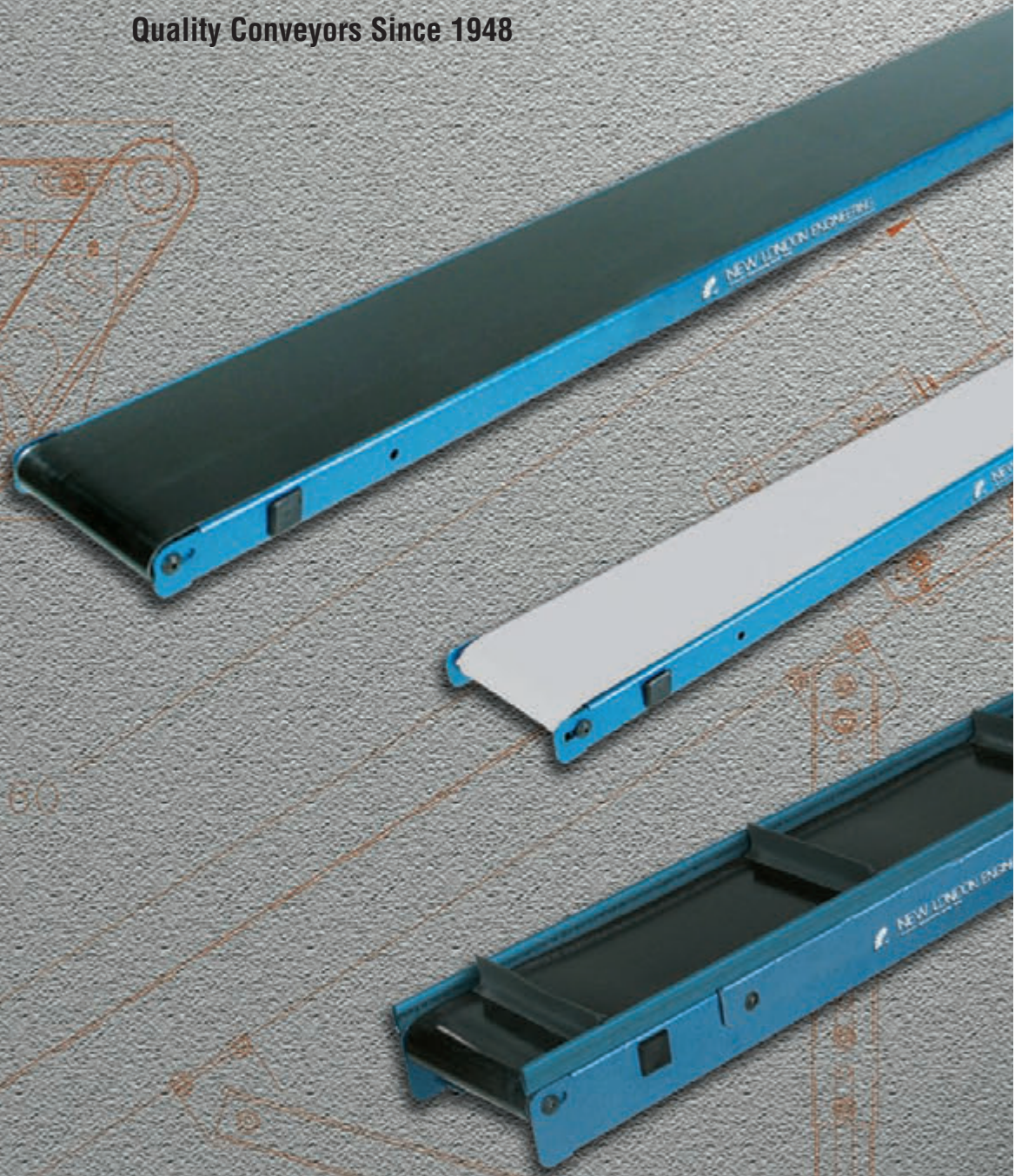

Quality Conveyors Since 1948



**ToughTrak-Tough & Durable Low-Profile Conveyors**

# ToughTrak Index

Design and Construction Features .....Page 2

ToughTrak Feature and Benefit Summary .....Page 3

Model 150 Drive Packages and Specifications.....Pages 4-7

Endless Belt Quick Change Illustration.....Page 8

Load Capacity Chart.....Page 8

Standard Speed Options .....Page 8

Model 250 Drive Packages and Specifications.....Pages 9-11

Cleated Belts .....Page 12

Stainless Steel .....Page 12

Siderail Options .....Page 12



## Quick Start Electrical Controls

New London Engineering stocks a wide variety of starters, electrical components and pre-wired fixed and pre-wired variable speed drive packages. Add a pre-wired Quick Start control package to your conveyor and it's ready to run when it arrives.

## Discharge

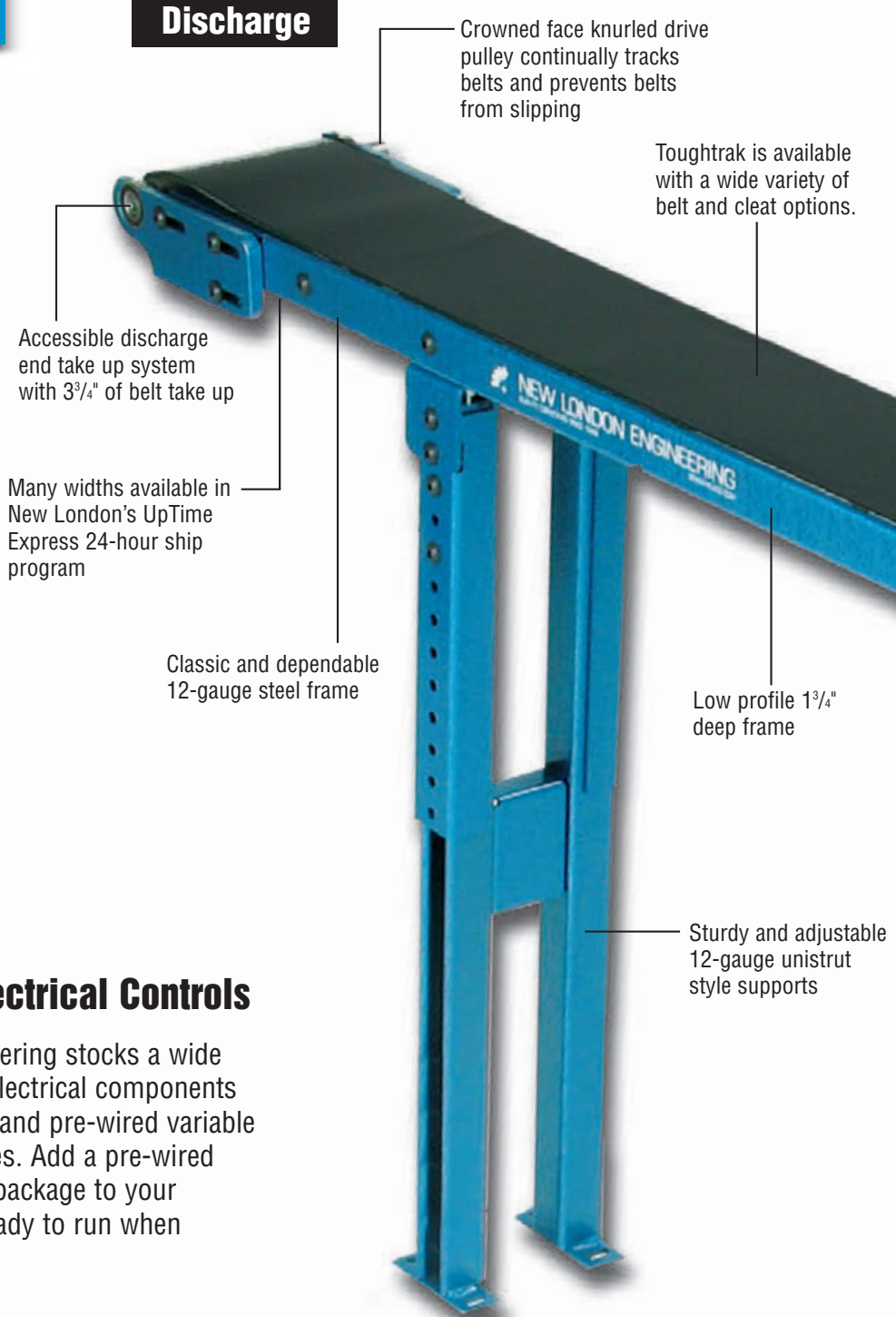

## ToughTrak Common Features

FRAME	INFEED PULLEY	DRIVE PULLEY FACE	STANDARD BELT	SUPPORTS
12 Gauge x 1 3/4" deep (FW = BW + 31/32")	1 5/16" Diameter Flat Face x 1/2" Bore	Crown Face Knurled	2-Ply Black PVC with #36 Unibar Lacing	Adjustable 12 Gauge Unistrut

# Design and Construction Features

## ToughTrak – Tough and Durable Low Profile Conveyors

ToughTrak low profile conveyors are lean and mean working machines. These steel fabricated, tough and durable conveyors are built to survive the extreme tests of the manufacturing environment. ToughTrak is not only built to last, they can be built to your exact length and width specifications at a cost lower than any other low profile conveyor.

ToughTrak Low Profile Conveyors are American made and American engineered to work harder and last longer than any competitor in its class. That's why they are called ToughTrak!

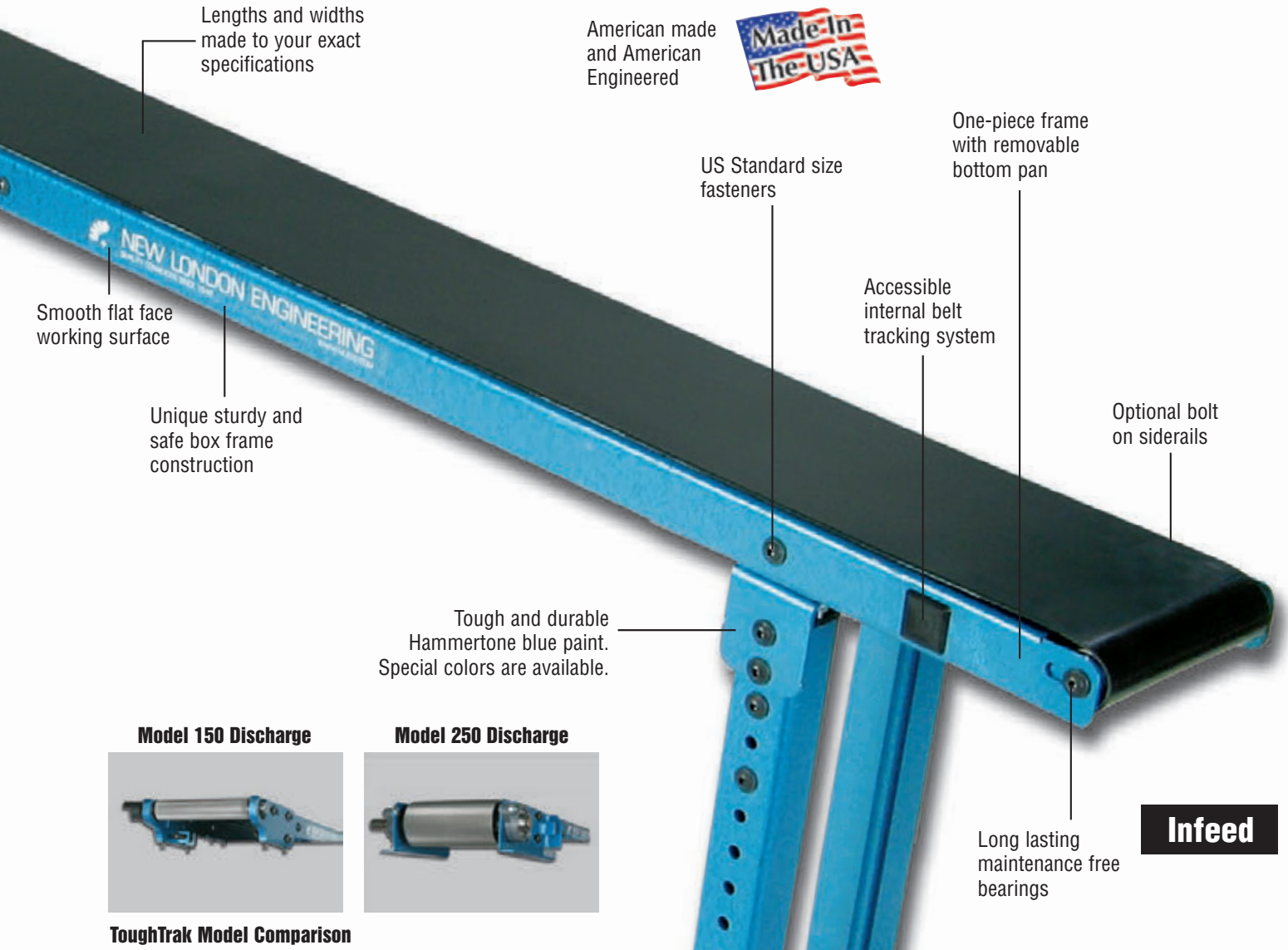

**Infeed**

**Model 150 Discharge**



**Model 250 Discharge**



**ToughTrak Model Comparison**

MODEL	APPLICATION	DRIVE PULLEY DIA.	DRIVE PULLEY BORE	DRIVE PULLEY BEARING	DRIVE PULLEY HEAD PLATE	DRIVE-MOTOR	TAKE UP/TRACKING
<b>Model 150</b>	Standard Duty Low Profile Applications	1 <sup>5</sup> / <sub>16</sub> "	5/8"	Pressed in Precision Bearings	Machined 1/2" Thick	Gearmotors	Internal @ Infeed Internal @ Discharge
<b>Model 250</b>	Heavy Duty Low Profile Applications	2 <sup>7</sup> / <sub>8</sub> "	3/4"	2 Bolt Flanged Grease Sealed	10 Gauge Formed	Motor-Reducer Combinations with 56 C Frames	Internal @ Infeed External @ Discharge

# ToughTrak Features and Benefits Summary

## 1. Tough & Durable Steel Construction

- With ToughTrak you don't have to compromise your conveyors length or width since its steel construction can be made to your exact lengths and widths. (Up to 24" wide and/or 20'6" long)
- ToughTrak is constructed with U.S. made hot rolled, high quality steel. ToughTrak is engineered to survive the extreme tests of the manufacturing environment.

## 2. Discharge end belt tension/take up system with a 3<sup>3</sup>/<sub>4</sub>" of belt take up

- Unlike the competition, ToughTrak's belt take up system is on the conveyor's discharge end and not at the infeed. Since the discharge end is often the most accessible end of the conveyor, belt tensioning is completed quick and easy.
- In some applications the belt will stretch and the resulting slack must be "taken up". ToughTrak is engineered to provide 3<sup>3</sup>/<sub>4</sub>" of belt take up (2<sup>1</sup>/<sub>2</sub>" at discharge and 1<sup>1</sup>/<sub>4</sub>" at infeed). This much take up means belts can be used longer saving you money, time and replacement part frustrations.

## 3. Rugged and Durable One piece, 12 gauge frame and bed with detachable bottom pan

- ToughTrak's frame and bed are laser cut from a single piece of steel providing a strong, smooth low friction slider bed surface.
- The formed frame includes a detachable bottom pan providing unmatched pinch point protection below the conveyors frame. ToughTrak's primary competitors cannot match this safety feature.

## 4. Bolt on Side Rails, Supports and Accessories

- The side rails, supports and accessories are easily installed and removed as necessary.

## 5. Quick belt change feature with U.S. standard fasteners

- When it's necessary to change a belt, hunting for metric wrenches or the costly special tool kit required by some competitors can be frustrating. American made ToughTrak eliminates this hassle since the belt can be changed with only one tool. Yes! ToughTrak belts can be changed in 10 minutes or less using only a <sup>3</sup>/<sub>16</sub>" Allen wrench. NOTE: the same wrench removes the supports and side rails.

## 6. Adjustable 12 Gauge Unistrut style supports

- These rugged and durable 12 gauge steel supports are designed to meet the demands of the manufacturing environment. ToughTrak supports are also readily adjustable.

## 7. Tough and Durable Hammertone Paint

- Specially formulated durable Hammertone Paint protects your investment against corrosion and cosmetic damage.

## 8. Belt Selection

- Describe your application and we will provide the right belt! New London Engineering stocks belts ranging from economical PVC to dependable Urethane. Quick delivery is not a problem since both lacing and endless belting capabilities are available on site.

## 9. Quick Shipments

- Many sizes and speeds are available in our UpTime Express – 24 hour ship program.

## 10. ToughTrak is American made and American Engineered



Open this page for a full view of Model 150 Drive Packages

# Model 150 Center Drives\*

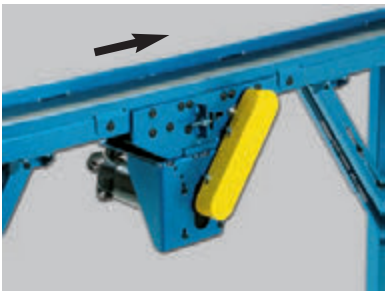

**Infeed**

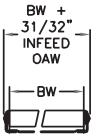

**Side**

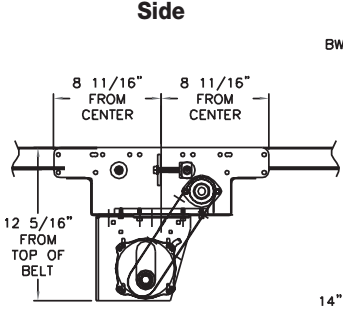

**Discharge**

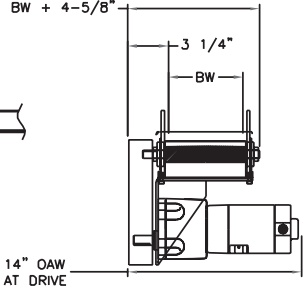

**DRIVE #1**    Center Drive\* • Bottom Mount • Inline Gearmotor • Under Belt

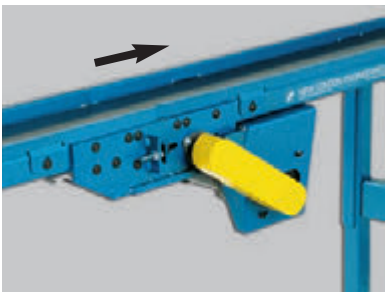

**Infeed**

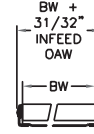

**Side**

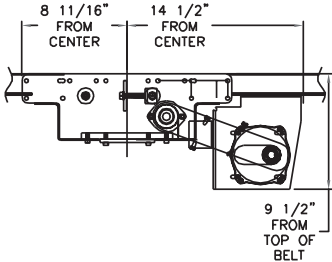

**Discharge**

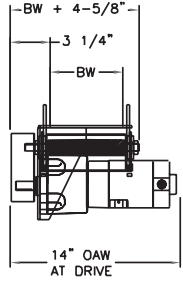

**DRIVE #2**    Center Drive\* • Frame Mount • Inline Gearmotor • Under Belt

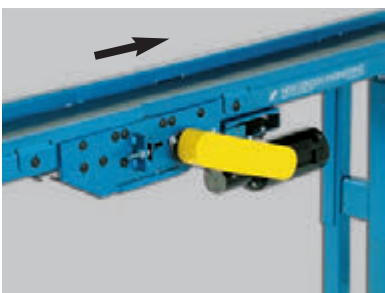

**Infeed**

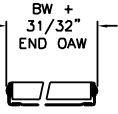

**Side**

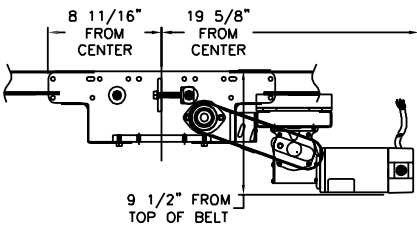

**Discharge**

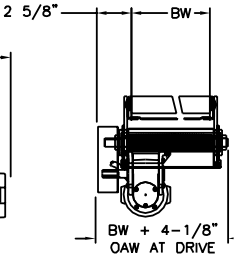

**DRIVE #3**    Center Drive\* • Frame Mount • Right Angle Gearmotor • Discharge Facing

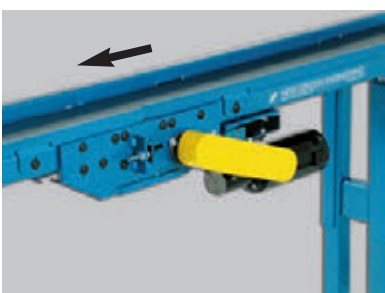

**Discharge**

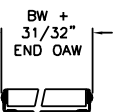

**Side**

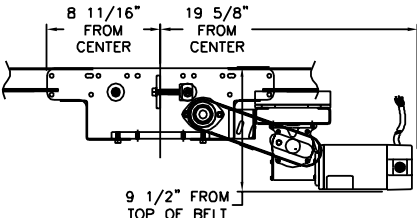

**Infeed**

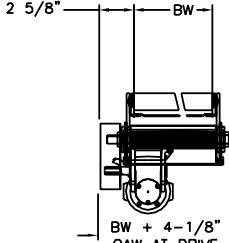

**DRIVE #4**    Center Drive\* • Frame Mount • Right Angle Gearmotor • Infeed Facing

\*Center mounts are typically mounted in the center (middle) of the conveyor.  
 If you require the mount location to be off center (closer to the infeed or discharge), please specify at time of order.  
 All 150 diagrams are shown with DC drives. All dimensions are subject to change.

# Model 150 Center Drives\*

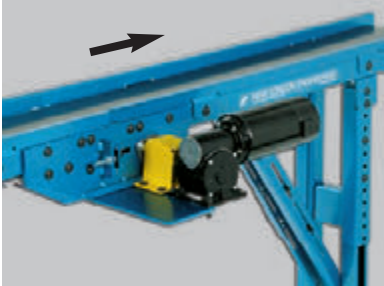
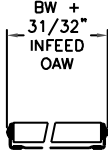
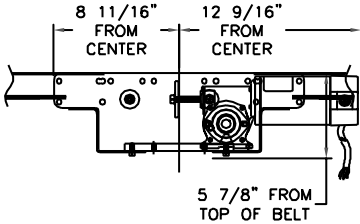
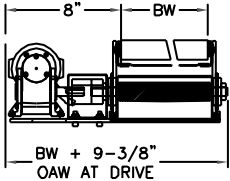
	Infeed	Side	Discharge
			
<b>DRIVE #5</b>	<b>Center Drive* • Shaft Mount • Right Angle Gearmotor • Discharge Facing</b>		

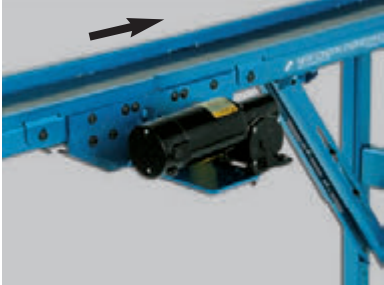
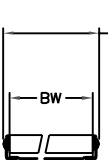
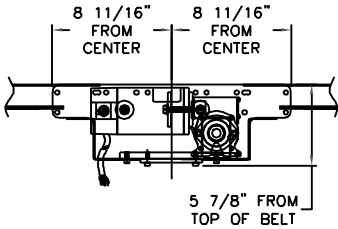
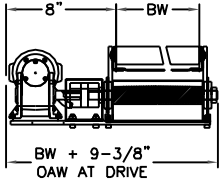
	Infeed	Side	Discharge
			
<b>DRIVE #6</b>	<b>Center Drive* • Shaft Mount • Right Angle Gearmotor • Infeed Facing</b>		

# Model 150 End Drives – Bottom Mounts

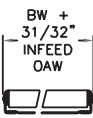
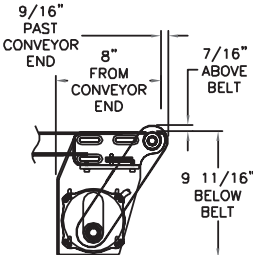
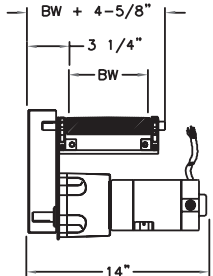
	Infeed	Side	Discharge
			
<b>DRIVE #7</b>	<b>End Drive • Bottom Mount • Inline Gearmotor • Under Belt</b>		

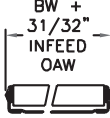
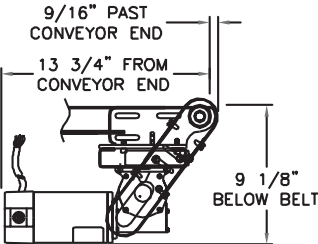
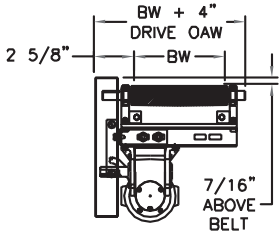
	Infeed	Side	Discharge
			
<b>DRIVE #8</b>	<b>End Drive • Bottom Mount • Right Angle Gearmotor • Infeed Facing</b>		

# Model 150 End Drives – Top Mounts



**Infeed**

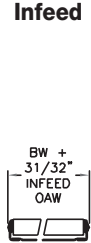

$BW + \frac{31}{32}"$   
INFEED  
OAW

**Side**

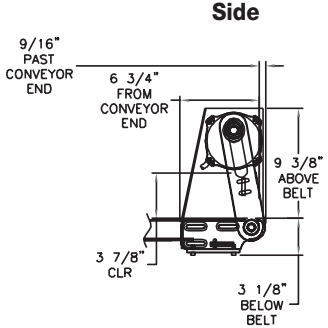

**Discharge**

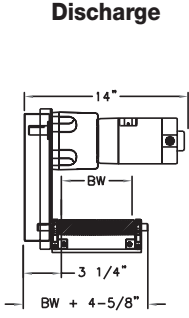

**DRIVE #9**      End Drive • Top Mount • Inline Gearmotor • Over Belt



**Infeed**



$BW + \frac{31}{32}"$   
INFEED  
OAW

**Side**

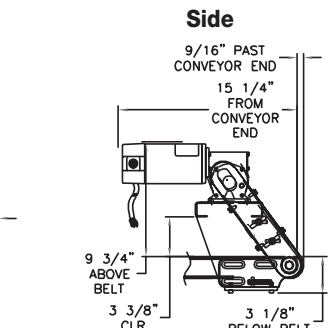

**Discharge**

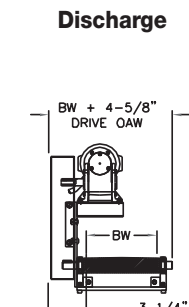

**DRIVE #10**      End Drive • Top Mount • Right Angle Gearmotor • Infeed Facing

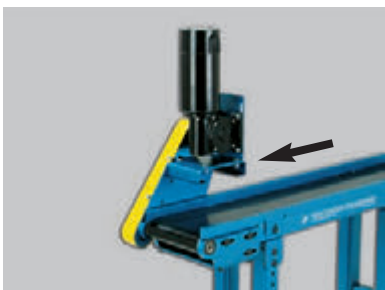

**Infeed**



$BW + \frac{31}{32}"$   
INFEED  
OAW

**Side**

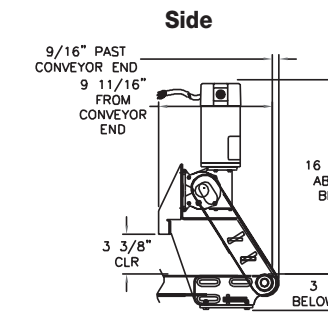

**Discharge**

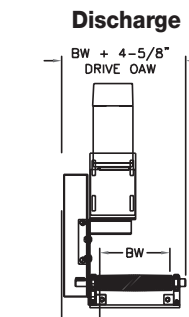

**DRIVE #11**      End Drive • Top Mount • Right Angle Gearmotor • Vertical Facing

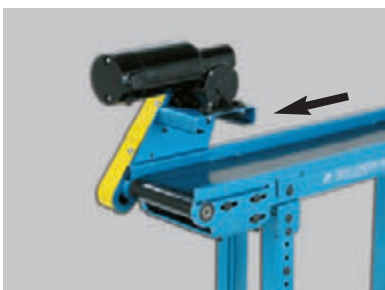

**Infeed**



$BW + \frac{31}{32}"$   
INFEED  
OAW

**Side**

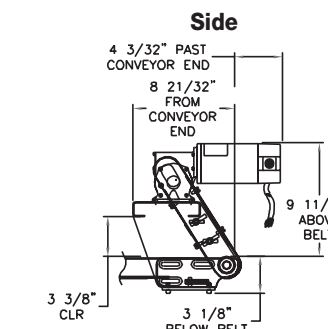

**Discharge**

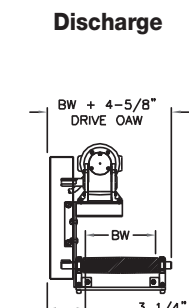

**DRIVE #12**      End Drive • Top Mount • Right Angle Gearmotor • Discharge Facing

# Model 150 End Drives – Shaft Mounts

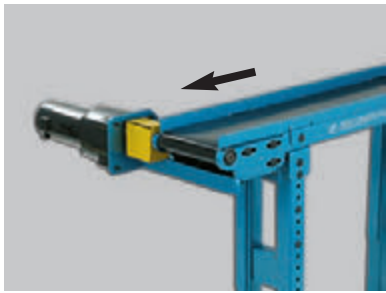

**Infeed**

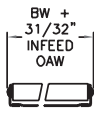

**Side**

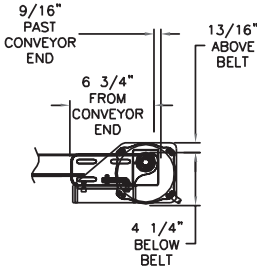

**Discharge**

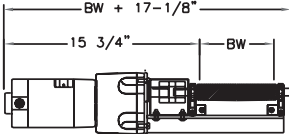

**DRIVE #13**
**End Drive • Shaft Mount • Inline Gearmotor • Side Facing**

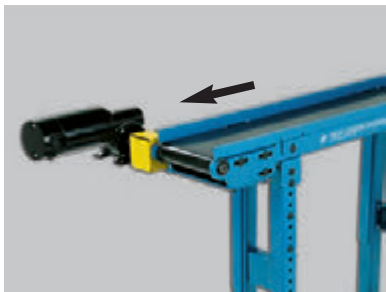

**Infeed**



**Side**

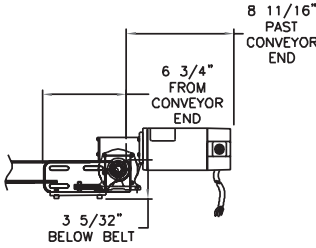

**Discharge**

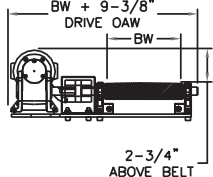

**DRIVE #14**
**End Drive • Shaft Mount • Right Angle Gearmotor • Discharge Facing**

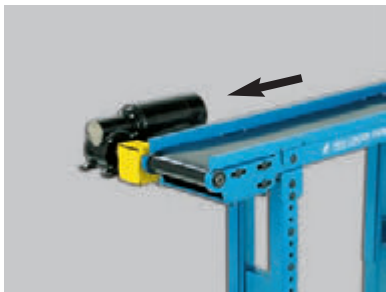

**Infeed**



**Side**

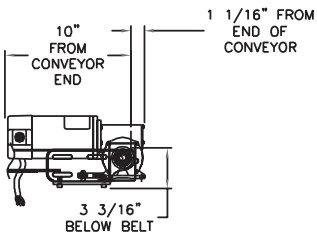

**Discharge**

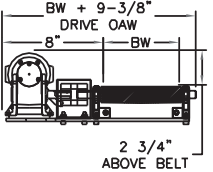

**DRIVE #15**
**End Drive • Shaft Mount • Right Angle Gearmotor • Infeed Facing**

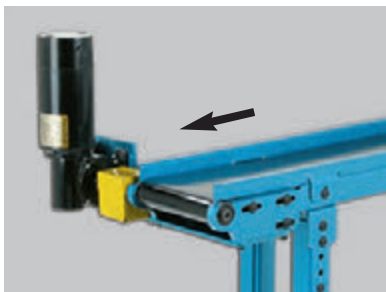

**Infeed**



**Side**

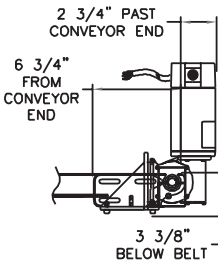

**Discharge**

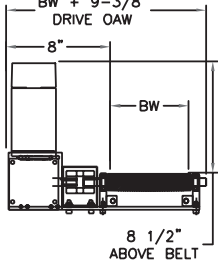

**DRIVE #16**
**End Drive • Shaft Mount • Right Angle Gearmotor • Vertical Facing**

# Endless Belt Quick Belt Change Feature

## Change Belts in 10 minutes or less

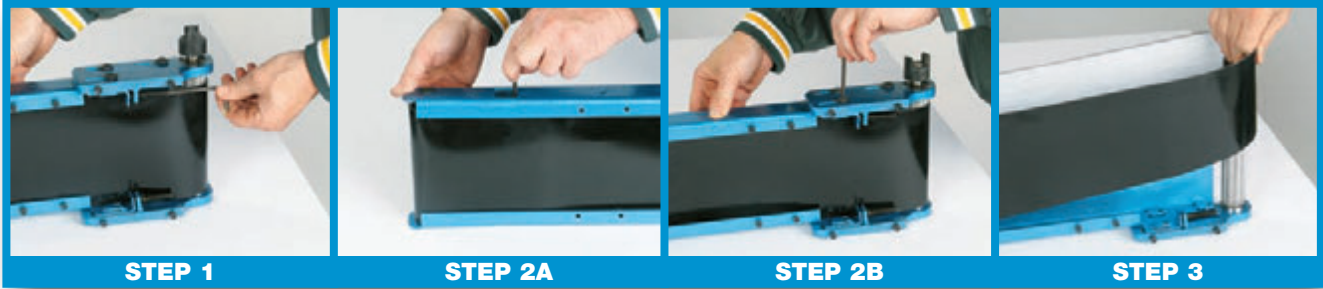

1. Loosen the socket head take up screws within the internal belt tension system.
2. Loosen the fasteners on both the infeed and drive pulleys and slide both pulleys toward the center of the conveyor. (Note: Try to slip the belt over the frame. If the belt will not slip over the frame, go to step 3.)
3. Remove the head plate from the drive end pulley. Slide the belt over the pulley and off the conveyor.

## Standard Speed Options

All speed options are available in Variable Speed. Other Speeds are available upon request.

### Model 150

3 PHASE RIGHT ANGLE 208/230/460/3/60		3 PHASE IN LINE 208/230/460/3/60		1 PHASE RIGHT ANGLE 115/1/60		1 PHASE IN LINE VOLTAGES ARE LISTED BELOW		DC RIGHT ANGLE 90V & 180V		DC IN LINE 90V & 180V		AIR MOTORS	
Speed – FPM	HP	Speed – FPM	HP	Speed FPM & Voltage	HP	Speed FPM & Voltage	HP	Speed – FPM	HP	Speed – FPM	HP	Speed – FPM	HP
15	1/4	59	1/3	14-115V	1/6	20-115V	1/6	20	1/6	21	1/4	15	1/20
29	1/4	118	1/3	28-115V	1/6	30-115 & 230V	1/3	30	1/6	28	1/4	30	1/10
58	1/4			57-115V	1/6	59-115 & 230V	1/3	59	1/6	57	1/4	60	1/5
117	1/4			110-115V	1/6	118-115 & 230V	1/3	119	1/6	86	1/4	120	1/3

### Model 250

HP	VOLTAGES	SPEEDS – FPM
1/3 HP & 1/2 HP 56 C Frame TEFC Motors and Reducers	115/230/1/60 & 230/460/3/60	15, 20, 25, 30, 35, 40, 45, 60, 90
1/4 HP & 1/2 HP 56 C Frame TEFC Motors and Reducers	90V & 180V DC	15, 20, 25, 30, 35, 40, 45, 60, 90

\*Uptime Express shipments are shaded in blue.

## Load Capacity Charts

WIDTH	2"	4"	6"	8"	10"	12"	14"	16"	18"	20"	22"	24"	
MAXIMUM LIVE LOAD	LIVE LOAD	LIVE LOAD	LIVE LOAD	LIVE LOAD	LIVE LOAD	LIVE LOAD	LIVE LOAD	LIVE LOAD	LIVE LOAD	LIVE LOAD	LIVE LOAD	LIVE LOAD	
MODEL 150	#	60	120	180	240	300	360	420	416	432	420	418	432
MODEL 250	#	84	168	252	336	420	504	588	640	648	640	660	648

\*Use this chart as a guideline only. Applications and drive selection factors will vary. Capacities are based on the following:  
Uniform, non-accumulating horizontal belt travel with the conveyor empty at start up and a pulling not pushing drive.

Open this page for a full view of Model 150 Drive Packages

# Model 250 Center Drives

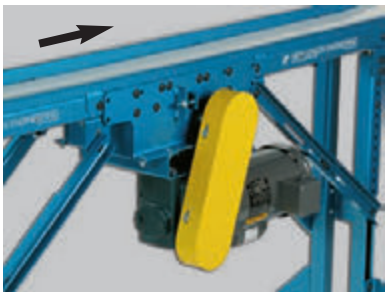

**Infeed**

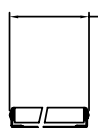

$BW + \frac{31}{32}''$   
INFEED OAW

**Side**

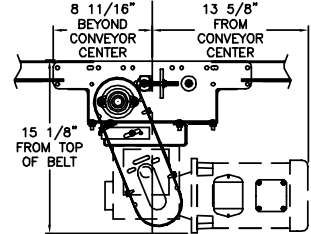

8  $\frac{11}{16}''$  BEYOND CONVEYOR CENTER  
13  $\frac{5}{8}''$  FROM CONVEYOR CENTER  
15  $\frac{1}{8}''$  FROM TOP OF BELT

**Discharge**

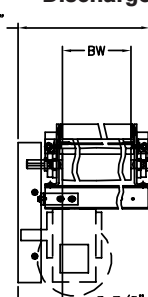

$BW + 5 - \frac{1}{2}''$   
DRIVE OAW

3  $\frac{7}{8}''$

**DRIVE #17**
**Center Drive • Bottom Mount • Discharge Facing**

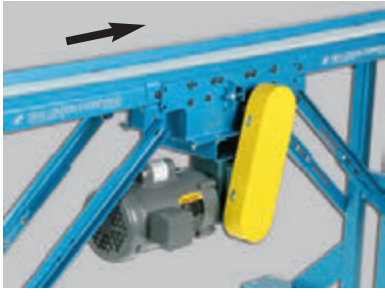

**Infeed**

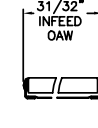

$BW + \frac{31}{32}''$   
INFEED OAW

**Side**

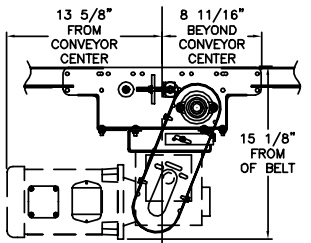

13  $\frac{5}{8}''$  FROM CONVEYOR CENTER  
8  $\frac{11}{16}''$  BEYOND CONVEYOR CENTER  
15  $\frac{1}{8}''$  FROM TOP OF BELT

**Discharge**

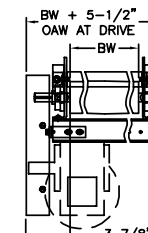

$BW + 5 - \frac{1}{2}''$   
OAW AT DRIVE

3  $\frac{7}{8}''$

**DRIVE #18**
**Center Drive • Bottom Mount • Infeed Facing**

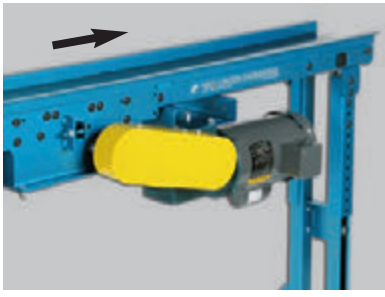

**Infeed**

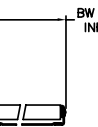

$BW + \frac{31}{32}''$   
INFEED OAW

**Side**

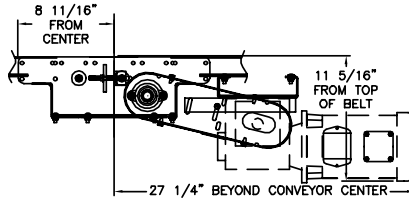

8  $\frac{11}{16}''$  FROM CENTER  
11  $\frac{5}{16}''$  FROM TOP OF BELT  
27  $\frac{1}{4}''$  BEYOND CONVEYOR CENTER

**Discharge**

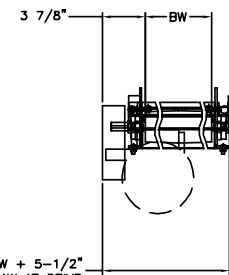

3  $\frac{7}{8}''$

$BW + 5 - \frac{1}{2}''$   
OAW AT DRIVE

**DRIVE #19**
**Center Drive • Frame Mount • Discharge Facing**

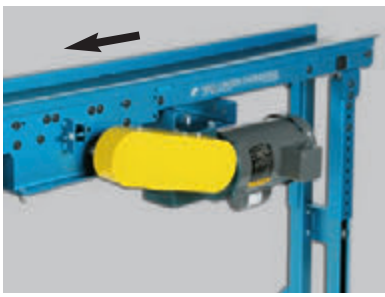

**Infeed**

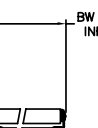

$BW + \frac{31}{32}''$   
INFEED OAW

**Side**

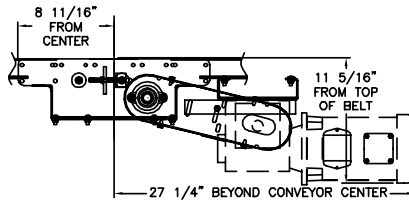

8  $\frac{11}{16}''$  FROM CENTER  
11  $\frac{5}{16}''$  FROM TOP OF BELT  
27  $\frac{1}{4}''$  BEYOND CONVEYOR CENTER

**Discharge**

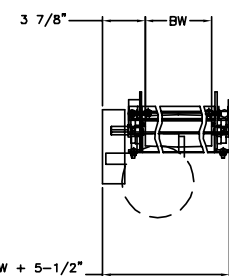

3  $\frac{7}{8}''$

$BW + 5 - \frac{1}{2}''$   
OAW AT DRIVE

**DRIVE #20**
**Center Drive • Frame Mount • Infeed Facing**

# Model 250 Center Drives

	<p><b>Infeed</b></p>	<p><b>Side</b></p>	<p><b>Discharge</b></p>
--	----------------------	--------------------	-------------------------

**DRIVE #21**

**Center Drive • Shaft Mount • Discharge Facing**

	<p><b>Infeed</b></p>	<p><b>Side</b></p>	<p><b>Discharge</b></p>
--	----------------------	--------------------	-------------------------

**DRIVE #22**

**Center Drive • Shaft Mount • Infeed Facing**

# Model 250 End Drives – Bottom Mounts

	<p><b>Infeed</b></p>	<p><b>Side</b></p>	<p><b>Discharge</b></p>
--	----------------------	--------------------	-------------------------

**DRIVE #23**

**End Drive • Bottom Mount • Infeed Facing**

# Model 250 End Drives – Top Mounts

	<p><b>Infeed</b></p>	<p><b>Side</b></p>	<p><b>Discharge</b></p>
--	----------------------	--------------------	-------------------------

**DRIVE #24**

**End Drive • Top Mount • Infeed Facing**

# Model 250 End Drives – Top Mounts

**Infeed**                      **Side**                      **Discharge**

**DRIVE #25**                      End Drive • Top Mount • Discharge Facing

# Model 250 End Drives – Side Mounts

**Infeed**                      **Side**                      **Discharge**

**DRIVE #26**                      End Drive • Side Mount • Infeed Facing

# Model 250 End Drives – Shaft Mounts

**Infeed**                      **Side**                      **Discharge**

**DRIVE #27**                      End Drive • Shaft Mount • Infeed Facing

**Infeed**                      **Side**                      **Discharge**

**DRIVE #28**                      End Drive • Shaft Mount • Discharge Facing

# Stainless Steel



## 12-Gauge Dull Mill #304-2B Finish

### Level 1 – Fully Loaded Stainless Steel Construction

All the conveyor components, hardware, belt lacing and options are produced with non magnetic stainless steel.

### Level 2 – Surface Component Stainless Steel Construction

All the surface and exposed components are replaced with non-magnetic stainless steel. All other components remain standard.

# Cleated Belts



Cleat Height	Base Width
1/2"	.96"
3/4"	.96"
1"	1.15"
1 1/2"	1.15"
2"	1.15"

Scooped Cleats	
1 1/4"	1.15"
2"	1.15"

# ToughTrak Side Rails

The standard rail height is 1". Other siderail options are listed below. Special heights and special designs are available upon request. All rails are available with UHMW lining.

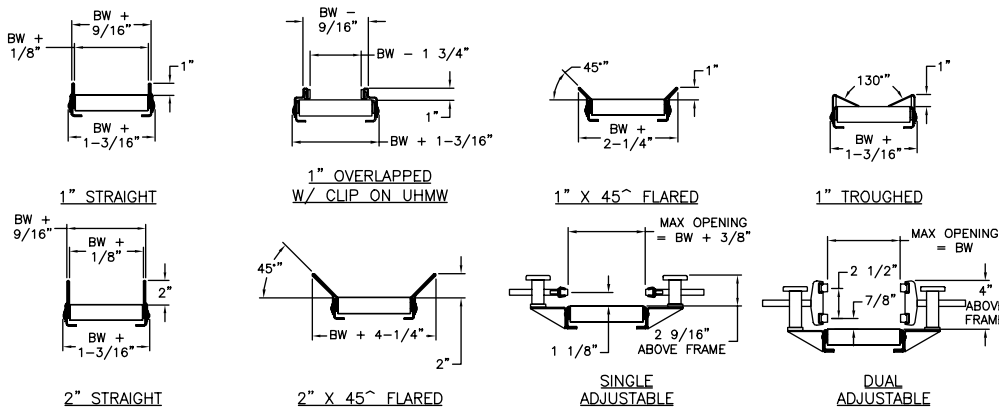

Open this page for a full view of Model 250 Drive Packages

# CUSTOM AND STANDARD CONVEYORS

**We are a full line conveyor supplier specializing in engineering high quality, quick delivery conveyors.**

- Accumulation Conveyors
- Belt Driven Live Roller Conveyors
- Bulk Material Handling Conveyors
- Cleated Belt Parts Conveyors
- Chain Driven Live Roller Conveyors
- Chain Transfers
- Drag Conveyors
- Floor-to-Floor Conveyors
- Gravity Roller
- Magnetic Conveyors
- Pallet Dispensers
- Power Roller Conveyors
- PlastiTrak – A full line of plastic belt conveyors
- Quick Start Electrical Controls
- Slat Conveyors
- Slider Bed Conveyors
- Specialty Conveyors
- SteelTrak – Hinged Steel Belt Conveyors
- ToughTrak – Tough and durable thin line conveyors
- Turntables
- UpTime Express – 24 hour shipments
- V-Belt Conveyors
- Wire Mesh Conveyors

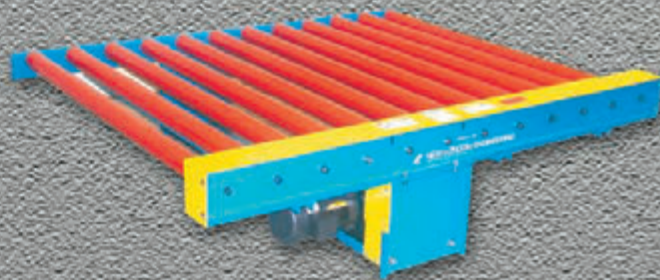

## REPLACEMENT PARTS

For easy part identification,  
go to [NLECO.com](http://NLECO.com) and  
click on Replacement Parts

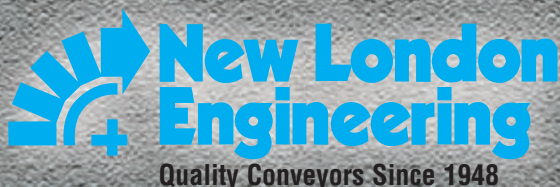

Quality Conveyors Since 1948

1700 Division Street • New London, WI 54961  
800-437-1994 • 920-982-4030 • fax: 920-982-6800

Brochure #TT07-07

[www.nleco.com](http://www.nleco.com)